

DRAINAGE REPORT

FOR

1215 CHAMBERS AVENUE

Eagle, Colorado

February 2026



Prepared by: Alpine Engineering, Inc.
P.O. Box 97
Edwards, CO 81632
(970) 926-3373

Prepared for: Morningstar Mountain Properties
Matthew Barry
(970) 390-7730

ALPINE
AEI
ENGINEERING INC.
34510 HWY 6 / UNIT A9 / PO BOX 97
EDWARDS CO 81632 / 970.926.3373
WWW.ALPINECIVIL.COM

TABLE OF CONTENTS

I. VICINITY MAP	
II. INTRODUCTION.....	1
III. SITE DESCRIPTION	1
IV. DRAINAGE BASINS	1
V. HYDROLOGY- PEAK FLOW DETERMINATION	2
VI. HYDRAULICS- CULVERTS & INLETS.....	2
VII. DETENTION	2
VIII. FLOODPLAIN.....	3
IX. SEDIMENT AND EROSION CONTROL	3
X. CDPHE PERMITS.....	3
XI. SUMMARY.....	3
XII. OFFSITE DRAINAGE	
• Appendix A – TR55 Drainage Basin Calculations	
• Appendix B – USDA-NRCS Soil Hydrologic Survey	
OFFSITE MAPS	
• Sheet 1 – Offsite Drainage Area Map 1”=400’	
• Sheet 2 – Offsite Vegetative Cover Drainage Area Map 1”=400’	
• Sheet 3 – Offsite Soils Drainage Area Map 1”=400’	
XIII. ONSITE DRAINAGE	
• Appendix D: NOAA Precipitation Data	
• Appendix E: USDA-NRCS Soil Hydrologic Survey	
• Appendix F: Historic and Developed “Stormwater Runoff Table”	
• Appendix G: Developed Flowrate Calculations (TR55)	
• Appendix H: Detention Pond- Storage Volume	
• Appendix I: Manning’s Equation for Onsite Storm Sewer and Curb/Gutter	
• Appendix J: Manning’s Equation for Access Drive Volume	
• Appendix K: MHFD Capacity for One-Half of Street and Ex. Inlet on Chambers Ave	

II. INTRODUCTION

The purpose of this Drainage Report is to summarize the existing hydrologic conditions found at the 1215 Chambers Avenue Storage Facility development and to evaluate the off-site and developed onsite stormwater runoff for the proposed project. This report contains calculations for off-site drainage and developed conditions including detention, and a description of anticipated Colorado Department of Public Health and Environment permits that will be acquired for the project. This report was completed in general conformance with the January 2018 Town of Eagle, Public Works Manual, Section 4.00, Drainage Analysis and Systems Design Criteria.

III. SITE DESCRIPTION

The proposed 1215 Chambers Avenue Parcel is located near the east end of Chambers Avenue between Interstate 70 and Chambers Avenue in the Town of Eagle, Colorado. The proposed developed site contains 5.38 acres (Lot C-13) and an adjacent 0.98 acres (Lot C 12B) which will be absorbed into this development through lot line vacation / replat. This report also addresses drainage from off-site areas north of Interstate 70 that outfalls onto this site in an existing 42inch corrugated metal pipe (CMP).

Most of the existing project parcel is a native grassed field. It is Lot C-13, Kemp Subdivision of the Eagle Valley Commercial Park. The off-site area is made up of pinyon and juniper and some grass and gravel roads.

IV. DRAINAGE BASINS

The drainage on the 1215 Chambers Avenue site flows predominately from north to south through some inlets and storm pipes and to the Eagle River. There is a 184.2 acre drainage

basin north of Interstate 70 that outfalls through a 42” CMP culvert onto the site. Refer to the Drainage Area Maps in this report. The Onsite Drainage Area Map shows each drainage basin that is collected by a storm sewer inlet and piped to the proposed stormwater detention pond. The Drainage Area Map includes the basin ID, basin size in acres and the 100 year stormwater volume to the specific basin.

V. HYDROLOGY- PEAK FLOW DETERMINATION

Overall site peak flows have been calculated using TR55, "Urban Hydrology for Small Watersheds", June 1986 as prepared by the U.S. Soil Conservation Service (SCS). The 24-hr precipitation values for various frequency storms were input into WIN TR55 based upon the 24-hour precipitation (P) values taken from the NOAA Atlas 2, Volume III, Isopluvials of 24-hour precipitation maps and were found to be 1.1-, 1.3-, 1.8-, 2.1- and 2.3- inches for the 2-, 5-, 25-, 50- and 100-year storms. TR55 stormwater flowrate calculations may be found in Appendix A (Offsite) and Appendix G for developed onsite flowrates. A spreadsheet for the stormwater values is contained in Appendix F and shown below. The off-site drainage area map using the USGS quad sheet for topography may be found on Sheet 1 of the map section of this report.

The vegetative cover for the off-site tributary drainage area may be found on Sheet 2 of the map section of this report.

The actual hydrologic soils group has been input based on the USDA NRCS Web Soil Survey of Hydrologic Soils Group and shown on Map Sheet 3 for the offsite drainage basins and in Appendix E for the onsite soils.

1215 Chambers Avenue Storage

Eagle, CO

Stormwater Runoff

Type B soils (per USDA)- entire onsite property

Basins	Area (Acre)	Area (sqft)	Area Impervious	Area Grass	RCN	TC (hours)	Q2 (cfs)	Q5 (cfs)	Q25 (cfs)	Q50 (cfs)	Q100 (cfs)
Contributing Basins											
5	0.05	2196	0.00	0.05	69	0.10	0.00	0.00	0.00	0.00	0.00
5a	0.05	2094	0.00	0.05	69	0.10	0.00	0.00	0.00	0.00	0.00
5b	0.12	5100	0.00	0.12	69	0.10	0.00	0.00	0.00	0.00	0.05
5c	0.06	2818	0.00	0.06	69	0.10	0.00	0.00	0.00	0.00	0.00
5d	0.05	2362	0.00	0.05	69	0.10	0.00	0.00	0.00	0.00	0.00
4e	0.60	25960	0.60	0.00	98	0.10	0.78	0.94	1.34	1.58	1.73
4w	0.40	17302	0.40	0.00	98	0.10	0.52	0.63	0.90	1.06	1.16
2e	0.40	17263	0.40	0.00	98	0.10	0.52	0.63	0.90	1.06	1.16
2w	0.43	18620	0.43	0.00	98	0.10	0.56	0.67	0.95	1.12	1.24
C	0.04	1845	0.03	0.01	89	0.10	0.00	0.00	0.05	0.07	0.08
B	0.37	15908	0.30	0.07	91	0.10	0.24	0.33	0.57	0.71	0.81
A	0.24	10529	0.20	0.04	92	0.10	0.18	0.24	0.40	0.49	0.56
1	0.47	20581	0.47	0.00	98	0.10	0.61	0.73	1.04	1.22	1.35
Roofs											
1-R	0.34	15014	0.34	0.00	98	0.10	0.44	0.53	0.75	0.89	0.98
2-R	0.30	13119	0.30	0.00	98	0.10	0.39	0.47	0.67	0.79	0.87
3-R	0.17	7608	0.17	0.00	98	0.10	0.22	0.27	0.38	0.45	0.50
4-R	0.33	14480	0.33	0.00	98	0.10	0.43	0.52	0.74	0.87	0.96
5-R	0.41	17754	0.41	0.00	98	0.10	0.53	0.64	0.91	1.07	1.18
6-R	0.29	12466	0.29	0.00	98	0.10	0.37	0.45	0.64	0.75	0.83
7-R	0.32	13750	0.32	0.00	98	0.10	0.41	0.50	0.71	0.84	0.92
Loading Docks											
L-1	0.08	3419	0.08	0.00	98	0.10	0.11	0.13	0.19	0.22	0.24
L-2	0.05	2071	0.05	0.00	98	0.10	0.07	0.08	0.11	0.13	0.15
L-3	0.03	1344	0.03	0.00	98	0.10	0.00	0.05	0.07	0.08	0.09
L-4	0.03	1100	0.03	0.00	98	0.10	0.00	0.05	0.07	0.08	0.09
L-5	0.12	5383	0.12	0.00	98	0.10	0.16	0.19	0.27	0.32	0.35
L-6	0.03	1220	0.03	0.00	98	0.10	0.00	0.05	0.07	0.08	0.09
L-7	0.10	4220	0.10	0.00	98	0.10	0.13	0.16	0.23	0.27	0.29
TOTAL DEVELOPED	5.87		5.43	0.45			6.67	8.26	11.96	14.15	15.68
Offsite											
O1	184.2		0	184,200	56	0.45	0.00	0.26	1.90	7.95	10.60
Historic											
Historic	6.30	274,460	0	6.30	69	0.123	0	0.81	2.92	4.68	5.16

The offsite drainage that is introduced onto the site from north of Interstate 70 has a 100 year flowrate of 10.6 cfs. This volume will be piped around the site to the east with the 42” pipe out falling into a proposed 10ft wide concrete drainage pan in a shared access drive and conveyed to Chambers Avenue curb and gutter and collected by an existing storm inlet.

The Historic flow of the undeveloped property was also analyzed to compare the undeveloped versus developed stormwater generated from various rainfall events. The 100 year undeveloped historic flowrate was computed to be 5.16 cfs and the developed 100 year storm flowrate was found to be 15.68 cfs. Almost all the developed runoff will be directed towards the proposed grass lined detention pond at the low point of the Project, on the south along Chambers Avenue and adjacent to the existing Town storm sewer system.

VI. HYDRAULICS- CULVERTS & INLETS

Various sized storm sewer piping is being proposed for the site. Sheet flow drainage in landscaped areas from the north part of the project area collected in 18" Nyloplast inlets and 12" HDPE storm piping. Roof drainage is collected via gutters and downspouts and routed to buried 6" PVC piping in the front (south) of each building. Sheet flow runoff from the paved parking areas flows to the south in each parking aisle and is collected in NDS trench drains and conveyed in buried 8" HDPE piping. Each buildings' delivery loading dock area has a trench drain to collect accumulated water. The 12", 8" and 6" pipes are connected in the center drive aisle and conveyed in an 18" HDPE collector pipe that travels south to the detention pond.

The trench drains in each parking area will be NDS duraslope HDPE pre-sloped 6" wide systems. Each basin with a trench drain was analyzed for clogging and the 100 year storm event. Appendix I contains the calculations for the curb/gutter to contain the 100 year event in the parking lot without overtopping the curb head in the event the trench drain becomes 100% clogged. All parking areas contained the 100 year event when the drains were clogged. The maximum depth of flow for the 100 year event ranged between 2.3" to 2.5" in the (4) parking areas with trench drains.

Appendix I also shows the calculation for the 18" collector pipe for the 100 year event, conveying the full developed stormwater flowrate of 14.78 cfs. At full capacity an 18" HDPE pipe at this slope can carry 21.4 cfs.

Appendix J contains the calculations pertaining to the offsite stormwater flows that outfall onto the property in the 42" culvert. The calculated 100 year storm offsite flowrate of 10.6 cfs will daylight in a new 10 ft wide concrete drainage pan that travels south to Chambers Avenue. The Manning's calculation for a trapezoidal concrete pan show that the 100 year flow will be at a depth of 3.0", allowing 2" of freeboard in the proposed pan (pan will be 5" deep).

Appendix K represents the volume that the existing Chambers Avenue can carry in the event of a 100 year storm event. The Mile High Flood District calculations show that half the roadway and curb/gutter can handle a flowrate of 20.8 cfs. The maximum flow to the street in a major event would be 11.48 cfs (10.6 from the Interstate 70 culvert and 0.88 cfs from the upstream drainage basin on Chambers Ave).

Appendix K also contains calculations relating to the existing 2'x3' curb inlet on Chambers Avenue (Mile High Flood District spreadsheet). The combination grated inlet can intercept 4.2 cfs (3.3 cfs with clogging factors applied). This inlet would intercept drainage from upstream asphalt along ½ of Chambers Road and the offsite basin from north of Interstate 70. This inlet interception volume is well over the volume of the 10 year Minor Storm event of 0.84 cfs, but below the 100 year volume of 11.48 cfs. The 25 year event could produce 2.5 cfs which could easily be intercepted in the existing curb inlet. Also, of note, there is a curb inlet directly perpendicular across the road that could help to increase interception in a storm event exceeding the 100 year flow.

VII. DETENTION

The detention volume has been calculated based upon an analysis performed in a Preliminary Drainage Study named Eagle Valley Commercial Park, A Resubdivision of Tract A, Eagle Valley Commercial Park, dated December 1, 1995 by Johnson & Kunkel Associates of Eagle Colorado. The 1995 Drainage Report explains regional detention has been provided for the subdivision, but each development lot will also need to provide 218 cu. ft. per acre of storage. This calculates to 6.38 acres (lot area) x 218 cu. ft. per acre = 1,391 cu. ft. Appendix H calculates the pond volume design shown on the Storm Sewer plans (C3.0 – C3.5)

VIII. FLOODPLAIN

There is no FEMA 100-year floodplain that is impacted by the development of this site.

IX. SEDIMENT AND EROSION CONTROL

A sediment and erosion control plan has been developed for the project to limit the transport of sediments and contaminants off-site during construction. Devices to be used during construction to prevent sediment laden runoff from leaving the site include stabilized construction entrances, erosion wattles, perimeter ditches, stone outlet structures and trench drain and inlet protection.

X. CDPHE PERMITS

The Colorado Department of Public Health and Environment (CDPHE) requires that proposed developments disturbing more than 1 acre of ground obtain a Colorado NPDES Stormwater Discharge Associated with Construction Activity permit from them.

XI. SUMMARY

The 1215 Chambers Avenue Project will have off-site stormwater conveyed around the eastern site to a wide concrete drainage pan that will flow to Chambers Avenue curb and gutter and to an existing storm sewer inlet in Chambers Avenue. The 100 year flowrate for the offsite basin was found to be 10.6 cfs and can be contained in the proposed drainage pan in the shared access drive and in Chambers Avenue. The existing inlet in Chamber Avenue can easily intercept the 25 year storm event, but not the full 100 year event from the offsite flows. The parking and drive aisles between all buildings cross slopes to trench drains. If the trench drains become clogged, the 100 year volume can still be contained by the curb/gutter and parking lot

asphalt. The proposed and existing 18” storm collector pipes can carry the 100 year storm event safely through and past the proposed development. Detention will be provided by a combination of regional stormwater management and some on-site detention.

APPENDIX A

Offsite Drainage

TR55 Drainage Basin Calculations

WinTR-55 Current Data Description

--- Identification Data ---

User: HM Date: 8/19/2021
 Project: 1215 Chambers Units: English
 SubTitle: Flow to existing I-70 42'' Culvert Areal Units: Acres
 State: Colorado
 County: Eagle
 Filename: O:\Eagle\1215 Chambers Storage-2021\dwg\Drainage\TR55\1215 Chambers-fair-good.w55

--- Sub-Area Data ---

Name	Description	Reach	Area (ac)	RCN	Tc
1A	1a	Outlet	184.2	56	0.453

Total area: 184.20 (ac)

--- Storm Data ---

Rainfall Depth by Rainfall Return Period

100-Yr (in)	50-Yr (in)	25-Yr (in)	10-Yr (in)	5-Yr (in)	2-Yr (in)	0-Yr (in)
2.9	2.8	2.4	2.0	1.8	1.4	.0

Storm Data Source: User-provided custom storm data
 Rainfall Distribution Type: Type II
 Dimensionless Unit Hydrograph: <standard>

=====
 HM 1215 Chambers
 Flow to existing I-70 42'' Culvert
 Eagle County, Colorado

Watershed Peak Table

Sub-Area or Reach Identifier	Peak Flow by Rainfall Return Period				
	100-Yr (cfs)	50-Yr (cfs)	25-Yr (cfs)	10-Yr (cfs)	2-Yr (cfs)

SUBAREAS					
1A	10.64	7.95	1.90	0.44	.00
REACHES					
OUTLET	10.64	7.95	1.90	0.44	.00

=====
 HM 1215 Chambers
 Flow to existing I-70 42'' Culvert

Eagle County, Colorado

Sub-Area Summary Table

Sub-Area Identifier	Drainage Area (ac)	Time of Concentration (hr)	Curve Number	Receiving Reach	Sub-Area Description
1A	184.20	0.453	56	Outlet	1a
Total Area: 184.20 (ac)					

HM 1215 Chambers
Flow to existing I-70 42'' Culvert
Eagle County, Colorado

Sub-Area Time of Concentration Details

Sub-Area Identifier/	Flow Length (ft)	Slope (ft/ft)	Mannings's n	End Area (sq ft)	Wetted Perimeter (ft)	Velocity (ft/sec)	Travel Time (hr)
1A							
SHEET	100	0.3400	0.400				0.174
SHALLOW	1048	0.2600	0.050				0.035
CHANNEL	3977	0.0580	0.050	3.00	6.00	4.528	0.244
Time of Concentration							0.453

HM 1215 Chambers
Flow to existing I-70 42'' Culvert
Eagle County, Colorado

Sub-Area Land Use and Curve Number Details

Sub-Area Identifier	Land Use	Hydrologic Soil Group	Sub-Area Area (ac)	Curve Number
1A	Open space; grass cover > 75%	(good) B	1.6	61
	Paved parking lots, roofs, driveways	B	2	98
	Gravel (w/ right-of-way)	A	1.09	76
	Gravel (w/ right-of-way)	B	.34	85
	Gravel (w/ right-of-way)	C	.06	89
	Gravel (w/ right-of-way)	D	.37	91
	Pinyon - juniper	(fair) D	34.74	80
	Pinyon - juniper	(good) B	19.3	41
	Pinyon - juniper	(good) C	41.74	61
	Sagebrush (w/ grass understory)	(fair) D	17.28	70
	Sagebrush (w/ grass understory)	(good) B	48.37	35
	Sagebrush (w/ grass understory)	(good) C	17.31	47
Total Area / Weighted Curve Number			184.2	56

APPENDIX B

USDA-NRCS Soil Hydrologic Soil Group Survey

Hydrologic Soil Group—Aspen-Gypsum Area, Colorado, Parts of Eagle, Garfield, and Pitkin Counties

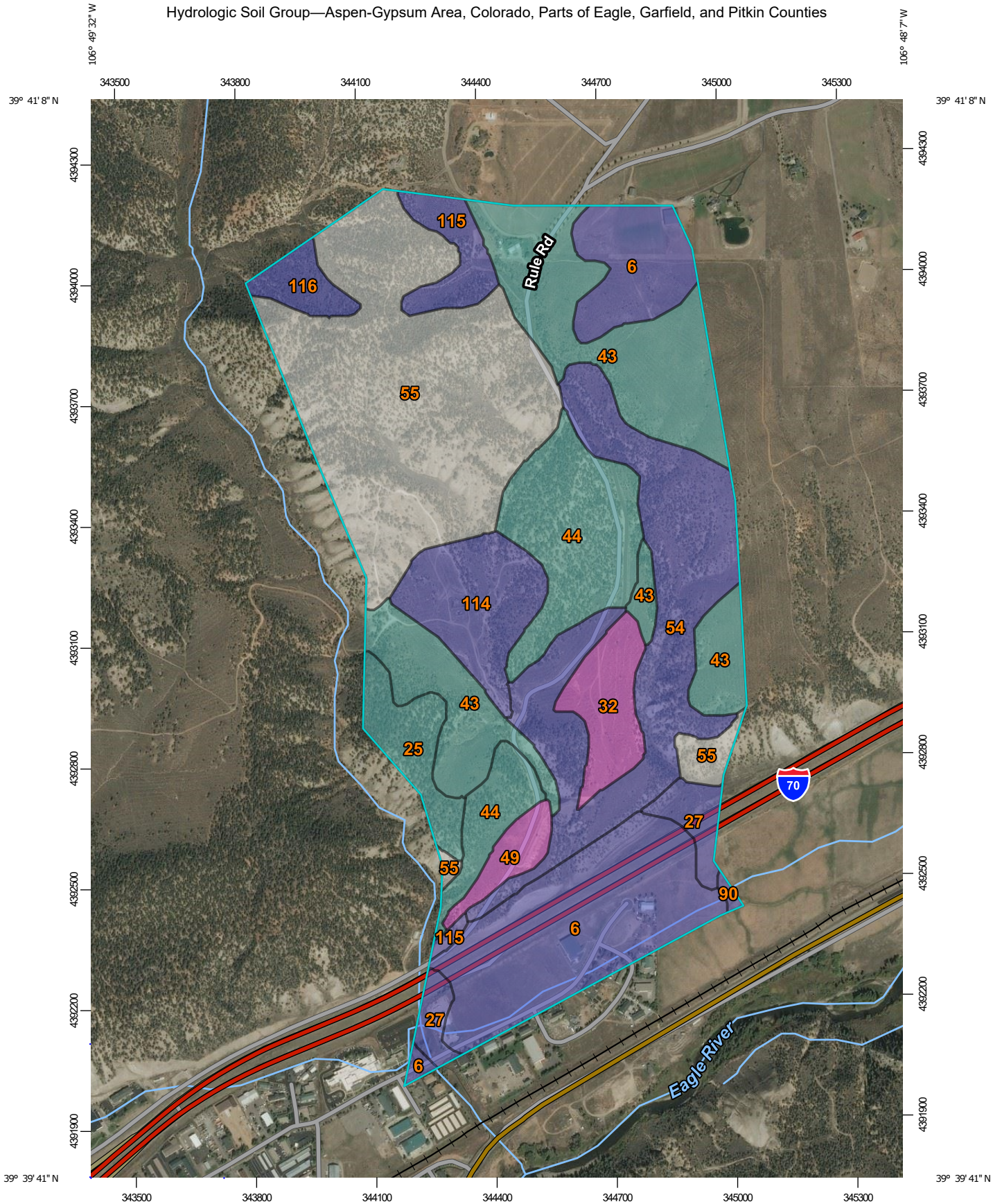

Map Scale: 1:13,100 if printed on A portrait (8.5" x 11") sheet.

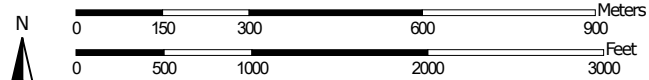

Map projection: Web Mercator Corner coordinates: WGS84 Edge tics: UTM Zone 13N WGS84



Natural Resources
Conservation Service

Web Soil Survey
National Cooperative Soil Survey

7/20/2021
Page 1 of 4

MAP LEGEND

Area of Interest (AOI)









 Area of Interest (AOI)

Soils

Soil Rating Polygons





 A
 A/D
 B
 B/D
 C
 C/D
 D
 Not rated or not available

Soil Rating Lines

 A
 A/D
 B
 B/D
 C
 C/D
 D
 Not rated or not available

Soil Rating Points





 A
 A/D
 B
 B/D

 C
 C/D
 D
 Not rated or not available

Water Features

 Streams and Canals

Transportation

 Rails
 Interstate Highways
 US Routes
 Major Roads
 Local Roads

Background

 Aerial Photography

MAP INFORMATION

The soil surveys that comprise your AOI were mapped at 1:24,000.

Please rely on the bar scale on each map sheet for map measurements.

Source of Map: Natural Resources Conservation Service
 Web Soil Survey URL:
 Coordinate System: Web Mercator (EPSG:3857)

Maps from the Web Soil Survey are based on the Web Mercator projection, which preserves direction and shape but distorts distance and area. A projection that preserves area, such as the Albers equal-area conic projection, should be used if more accurate calculations of distance or area are required.

This product is generated from the USDA-NRCS certified data as of the version date(s) listed below.

Soil Survey Area: Aspen-Gypsum Area, Colorado, Parts of Eagle, Garfield, and Pitkin Counties
 Survey Area Data: Version 11, Jun 5, 2020

Soil map units are labeled (as space allows) for map scales 1:50,000 or larger.

Date(s) aerial images were photographed: Aug 15, 2012—Sep 24, 2015

The orthophoto or other base map on which the soil lines were compiled and digitized probably differs from the background imagery displayed on these maps. As a result, some minor shifting of map unit boundaries may be evident.

Hydrologic Soil Group

Map unit symbol	Map unit name	Rating	Acres in AOI	Percent of AOI
6	Almy loam, 1 to 12 percent slopes	B	72.3	16.1%
25	Cushool-Rentsac complex, 15 to 65 percent slopes	C	12.9	2.9%
27	Dahlquist-Southace complex, 12 to 25 percent slopes	B	10.1	2.2%
32	Dotsero sandy loam, 1 to 12 percent slopes	A	14.5	3.2%
43	Forelle-Brownsto complex, 6 to 12 percent slopes	C	73.5	16.4%
44	Forelle-Brownsto complex, 12 to 25 percent slopes	C	43.2	9.6%
49	Goslin fine sandy loam, 3 to 6 percent slopes	A	6.6	1.5%
54	Grotte gravelly loam, 25 to 65 percent slopes	B	66.4	14.8%
55	Gypsum land-Gypsiorthids complex, 12 to 65 percent slopes		107.7	24.0%
90	Mussel loam, 6 to 12 percent slopes	B	0.7	0.2%
114	Yamo loam, 1 to 6 percent slopes	B	23.6	5.3%
115	Yamo loam, 6 to 12 percent slopes	B	10.6	2.4%
116	Yamo loam, 12 to 25 percent slopes	B	6.7	1.5%
Totals for Area of Interest			448.8	100.0%

Description

Hydrologic soil groups are based on estimates of runoff potential. Soils are assigned to one of four groups according to the rate of water infiltration when the soils are not protected by vegetation, are thoroughly wet, and receive precipitation from long-duration storms.

The soils in the United States are assigned to four groups (A, B, C, and D) and three dual classes (A/D, B/D, and C/D). The groups are defined as follows:

Group A. Soils having a high infiltration rate (low runoff potential) when thoroughly wet. These consist mainly of deep, well drained to excessively drained sands or gravelly sands. These soils have a high rate of water transmission.

Group B. Soils having a moderate infiltration rate when thoroughly wet. These consist chiefly of moderately deep or deep, moderately well drained or well drained soils that have moderately fine texture to moderately coarse texture. These soils have a moderate rate of water transmission.

Group C. Soils having a slow infiltration rate when thoroughly wet. These consist chiefly of soils having a layer that impedes the downward movement of water or soils of moderately fine texture or fine texture. These soils have a slow rate of water transmission.

Group D. Soils having a very slow infiltration rate (high runoff potential) when thoroughly wet. These consist chiefly of clays that have a high shrink-swell potential, soils that have a high water table, soils that have a claypan or clay layer at or near the surface, and soils that are shallow over nearly impervious material. These soils have a very slow rate of water transmission.

If a soil is assigned to a dual hydrologic group (A/D, B/D, or C/D), the first letter is for drained areas and the second is for undrained areas. Only the soils that in their natural condition are in group D are assigned to dual classes.

Rating Options

Aggregation Method: Dominant Condition

Component Percent Cutoff: None Specified

Tie-break Rule: Higher

MAPS

OFFSITE DRAINAGE

OFFSITE DRAINAGE AREA MAP

O:\Eagle\1215 Chambers Storage-2021\dwg\Drainage\1215-Chambers.dwg, 01-DAM, 7/21/2021 9:32:22 AM, Mues, Mues



1215 CHAMBERS AVENUE
STORAGE FACILITY - EAGLE, COLORADO
DRAINAGE AREA MAP

NO.	DATE	REVISIONS	BY

DESIGNED MCW	
DRAWN MCW	
CHECKED MCW	
JOB NO.	
DATE	07.20.2021

OFFSITE VEGETATION COVER MAP

O:\Eagle\1215 Chambers Storage-2021\dwg\Drainage\1215-Chambers.dwg, 02-DAM-COVER, 8/2/2021 3:14:58 PM, Mues, Mues



**1215 CHAMBERS AVENUE
STORAGE FACILITY - EAGLE, COLORADO
VEGETATIVE COVER DRAINAGE AREA MAP**

DESIGNED	MCW	DATE
		07.20.2021
DRAWN	MCW	
CHECKED	MCW	
JOB NO.		
DATE		

OFFSITE SOILS DRAINAGE AREA MAP

O:\Eagle\1215 Chambers Storage-2021\dwg\Drainage\1215-Chambers.dwg, 03-DAM-SOILS, 7/21/2021 9:34:43 AM, Mues, Mues

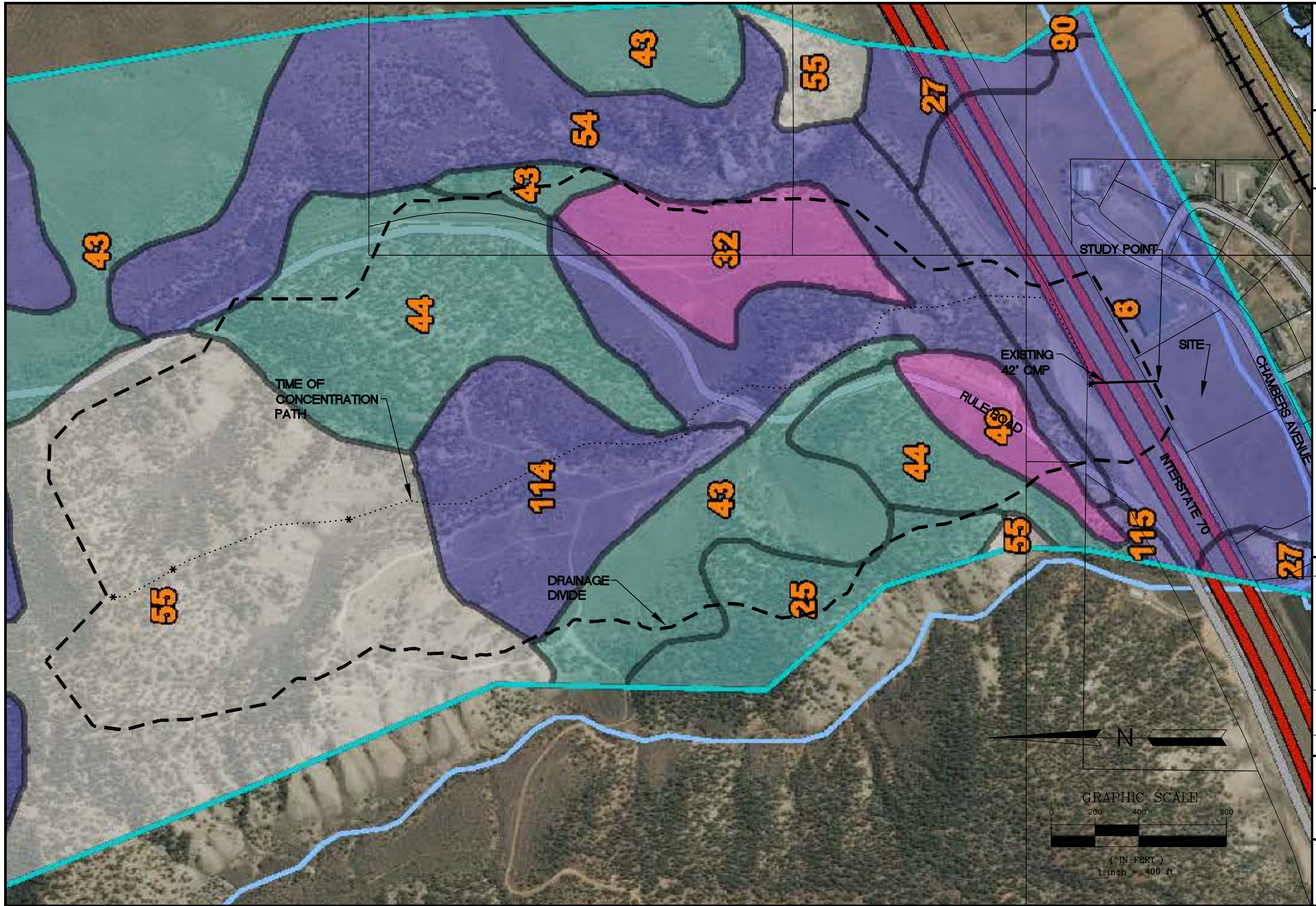

1215 CHAMBERS AVENUE
STORAGE FACILITY - EAGLE, COLORADO
SOILS DRAINAGE AREA MAP

NO.	DATE	REVISIONS	BY

DESIGNED MCW	
DRAWN MCW	
CHECKED MCW	
JOB NO.	
DATE	07.20.2021

APPENDIX D

Onsite Drainage

NOAA Precipitation Data



NOAA Atlas 14, Volume 8, Version 2
Location name: Eagle, Colorado, USA*
Latitude: 39.6665°, Longitude: -106.8124°
Elevation: 6680 ft**
 * source: ESRI Maps
 ** source: USGS



POINT PRECIPITATION FREQUENCY ESTIMATES

Sanja Perica, Deborah Martin, Sandra Pavlovic, Ishani Roy, Michael St. Laurent, Carl Trypaluk, Dale Unruh, Michael Yekta, Geoffery Bonnin

NOAA, National Weather Service, Silver Spring, Maryland

[PF_tabular](#) | [PF_graphical](#) | [Maps_&_aerials](#)

PF tabular

PDS-based point precipitation frequency estimates with 90% confidence intervals (in inches)¹										
Duration	Average recurrence interval (years)									
	1	2	5	10	25	50	100	200	500	1000
5-min	0.104 (0.085-0.129)	0.156 (0.127-0.195)	0.240 (0.195-0.301)	0.308 (0.249-0.389)	0.400 (0.307-0.527)	0.469 (0.350-0.631)	0.537 (0.385-0.748)	0.604 (0.411-0.874)	0.690 (0.448-1.04)	0.753 (0.477-1.16)
10-min	0.152 (0.124-0.189)	0.228 (0.186-0.285)	0.351 (0.286-0.441)	0.451 (0.364-0.570)	0.586 (0.449-0.771)	0.687 (0.513-0.924)	0.786 (0.563-1.10)	0.884 (0.602-1.28)	1.01 (0.657-1.52)	1.10 (0.698-1.70)
15-min	0.185 (0.151-0.231)	0.279 (0.227-0.348)	0.429 (0.348-0.537)	0.550 (0.444-0.695)	0.714 (0.548-0.941)	0.838 (0.626-1.13)	0.958 (0.687-1.34)	1.08 (0.734-1.56)	1.23 (0.801-1.86)	1.34 (0.851-2.08)
30-min	0.258 (0.211-0.322)	0.353 (0.288-0.441)	0.509 (0.414-0.638)	0.639 (0.516-0.806)	0.819 (0.632-1.08)	0.959 (0.719-1.30)	1.10 (0.791-1.54)	1.24 (0.849-1.81)	1.43 (0.935-2.17)	1.58 (1.00-2.44)
60-min	0.336 (0.275-0.419)	0.427 (0.348-0.533)	0.579 (0.470-0.726)	0.708 (0.572-0.894)	0.893 (0.691-1.19)	1.04 (0.782-1.41)	1.19 (0.858-1.67)	1.35 (0.922-1.96)	1.56 (1.02-2.36)	1.72 (1.09-2.66)
2-hr	0.414 (0.341-0.513)	0.500 (0.411-0.620)	0.648 (0.531-0.807)	0.778 (0.632-0.974)	0.966 (0.757-1.28)	1.12 (0.851-1.51)	1.28 (0.932-1.78)	1.45 (1.00-2.09)	1.68 (1.11-2.52)	1.87 (1.20-2.85)
3-hr	0.477 (0.394-0.588)	0.555 (0.458-0.685)	0.692 (0.569-0.857)	0.815 (0.665-1.02)	0.996 (0.786-1.31)	1.15 (0.877-1.54)	1.31 (0.958-1.81)	1.48 (1.03-2.12)	1.72 (1.14-2.55)	1.91 (1.23-2.88)
6-hr	0.609 (0.506-0.744)	0.685 (0.569-0.838)	0.821 (0.679-1.01)	0.944 (0.775-1.16)	1.13 (0.898-1.47)	1.28 (0.991-1.70)	1.45 (1.07-1.98)	1.63 (1.15-2.31)	1.88 (1.27-2.76)	2.08 (1.36-3.10)
12-hr	0.758 (0.635-0.919)	0.867 (0.725-1.05)	1.05 (0.877-1.28)	1.22 (1.01-1.49)	1.45 (1.16-1.86)	1.64 (1.28-2.14)	1.84 (1.37-2.48)	2.05 (1.46-2.86)	2.34 (1.59-3.38)	2.57 (1.69-3.77)
24-hr	0.928 (0.782-1.12)	1.07 (0.901-1.29)	1.31 (1.10-1.58)	1.52 (1.27-1.85)	1.82 (1.46-2.30)	2.06 (1.61-2.65)	2.30 (1.73-3.06)	2.56 (1.83-3.52)	2.91 (2.00-4.14)	3.19 (2.12-4.61)
2-day	1.12 (0.947-1.33)	1.27 (1.08-1.52)	1.54 (1.30-1.85)	1.78 (1.49-2.14)	2.12 (1.72-2.66)	2.40 (1.89-3.06)	2.69 (2.04-3.54)	3.00 (2.17-4.07)	3.43 (2.37-4.80)	3.76 (2.53-5.36)
3-day	1.23 (1.05-1.46)	1.41 (1.20-1.67)	1.70 (1.44-2.03)	1.96 (1.65-2.35)	2.34 (1.90-2.92)	2.64 (2.10-3.35)	2.96 (2.26-3.86)	3.30 (2.40-4.44)	3.76 (2.62-5.22)	4.12 (2.78-5.82)
4-day	1.33 (1.14-1.57)	1.52 (1.29-1.80)	1.83 (1.56-2.18)	2.11 (1.78-2.51)	2.50 (2.04-3.11)	2.82 (2.24-3.56)	3.15 (2.41-4.09)	3.50 (2.55-4.68)	3.98 (2.78-5.49)	4.35 (2.95-6.10)
7-day	1.59 (1.36-1.86)	1.78 (1.53-2.10)	2.11 (1.80-2.49)	2.40 (2.04-2.84)	2.81 (2.30-3.45)	3.14 (2.51-3.92)	3.48 (2.68-4.46)	3.83 (2.82-5.07)	4.32 (3.05-5.89)	4.71 (3.22-6.51)
10-day	1.81 (1.56-2.12)	2.01 (1.73-2.36)	2.36 (2.02-2.76)	2.65 (2.26-3.12)	3.07 (2.53-3.76)	3.41 (2.74-4.24)	3.76 (2.91-4.80)	4.13 (3.06-5.42)	4.64 (3.29-6.27)	5.03 (3.46-6.91)
20-day	2.42 (2.10-2.81)	2.68 (2.32-3.11)	3.11 (2.68-3.62)	3.47 (2.98-4.06)	3.98 (3.31-4.80)	4.39 (3.55-5.37)	4.80 (3.75-6.03)	5.23 (3.90-6.75)	5.81 (4.16-7.71)	6.25 (4.35-8.44)
30-day	2.94 (2.56-3.38)	3.25 (2.83-3.75)	3.78 (3.27-4.37)	4.21 (3.63-4.89)	4.81 (4.00-5.75)	5.27 (4.28-6.39)	5.73 (4.49-7.13)	6.20 (4.65-7.93)	6.83 (4.92-8.97)	7.30 (5.12-9.76)
45-day	3.60 (3.15-4.13)	4.00 (3.50-4.60)	4.65 (4.05-5.35)	5.17 (4.48-5.98)	5.88 (4.90-6.96)	6.40 (5.22-7.69)	6.92 (5.44-8.51)	7.43 (5.59-9.39)	8.08 (5.84-10.5)	8.56 (6.04-11.3)
60-day	4.18 (3.67-4.78)	4.66 (4.08-5.33)	5.41 (4.72-6.21)	6.01 (5.22-6.92)	6.80 (5.67-7.99)	7.37 (6.02-8.80)	7.92 (6.24-9.67)	8.44 (6.38-10.6)	9.10 (6.60-11.7)	9.56 (6.78-12.6)

¹ Precipitation frequency (PF) estimates in this table are based on frequency analysis of partial duration series (PDS). Numbers in parenthesis are PF estimates at lower and upper bounds of the 90% confidence interval. The probability that precipitation frequency estimates (for a given duration and average recurrence interval) will be greater than the upper bound (or less than the lower bound) is 5%. Estimates at upper bounds are not checked against probable maximum precipitation (PMP) estimates and may be higher than currently valid PMP values. Please refer to NOAA Atlas 14 document for more information.

[Back to Top](#)

PF graphical

PDS-based depth-duration-frequency (DDF) curves
 Latitude: 39.6665°, Longitude: -106.8124°

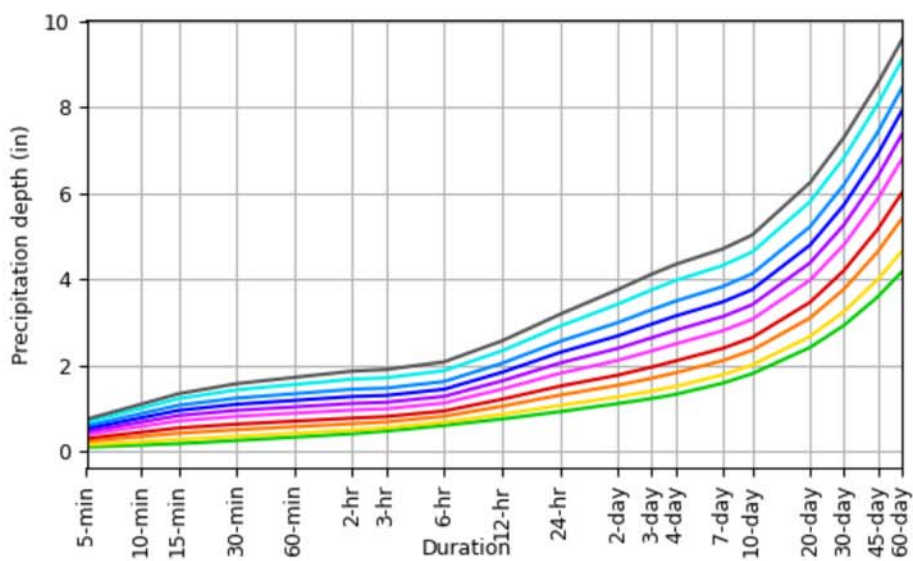

Average recurrence interval (years)
1
2
5
10
25
50
100
200
500
1000

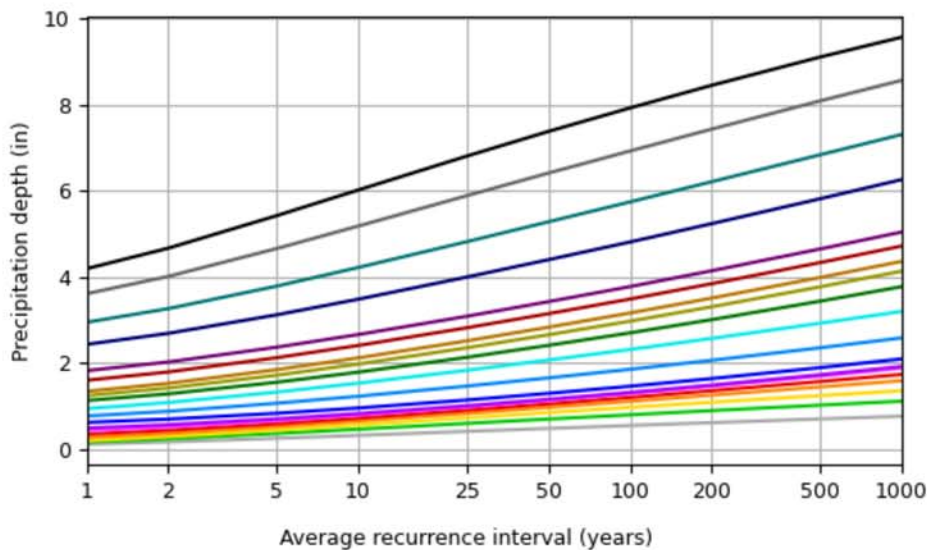

Duration	
5-min	2-day
10-min	3-day
15-min	4-day
30-min	7-day
60-min	10-day
2-hr	20-day
3-hr	30-day
6-hr	45-day
12-hr	60-day
24-hr	

[Back to Top](#)

Maps & aerials

Small scale terrain

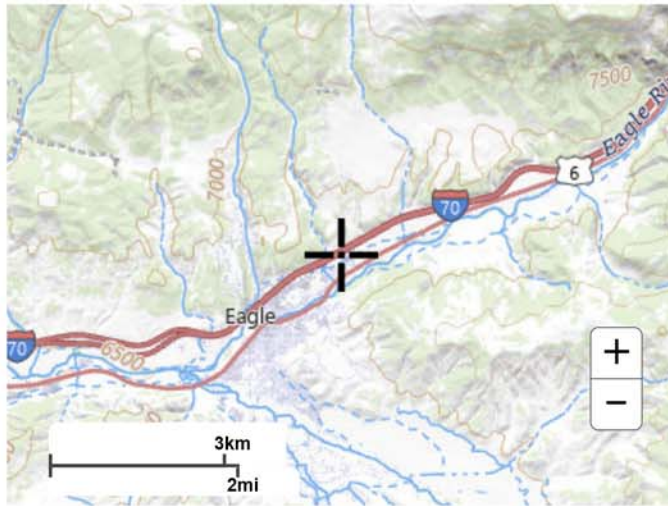

Large scale terrain



Large scale map



Large scale aerial

APPENDIX E

Onsite Drainage

USDA NRCS Soil Hydrologic Survey

Hydrologic Soil Group—Aspen-Gypsum Area, Colorado, Parts of Eagle, Garfield, and Pitkin Counties



Map Scale: 1:1,780 if printed on A landscape (11" x 8.5") sheet.

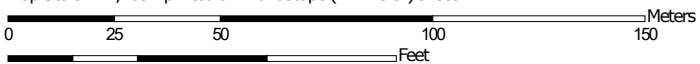

Map projection: Web Mercator Corner coordinates: WGS84 Edge tics: UTM Zone 13N WGS84



MAP LEGEND

Area of Interest (AOI)









 Area of Interest (AOI)

Soils

Soil Rating Polygons





 A
 A/D
 B
 B/D
 C
 C/D
 D
 Not rated or not available

Soil Rating Lines

 A
 A/D
 B
 B/D
 C
 C/D
 D
 Not rated or not available

Soil Rating Points





 A
 A/D
 B
 B/D

 C
 C/D
 D
 Not rated or not available

Water Features

 Streams and Canals

Transportation

 Rails
 Interstate Highways
 US Routes
 Major Roads
 Local Roads

Background

 Aerial Photography

MAP INFORMATION

The soil surveys that comprise your AOI were mapped at 1:24,000.

Warning: Soil Map may not be valid at this scale.

Enlargement of maps beyond the scale of mapping can cause misunderstanding of the detail of mapping and accuracy of soil line placement. The maps do not show the small areas of contrasting soils that could have been shown at a more detailed scale.

Please rely on the bar scale on each map sheet for map measurements.

Source of Map: Natural Resources Conservation Service
 Web Soil Survey URL:
 Coordinate System: Web Mercator (EPSG:3857)

Maps from the Web Soil Survey are based on the Web Mercator projection, which preserves direction and shape but distorts distance and area. A projection that preserves area, such as the Albers equal-area conic projection, should be used if more accurate calculations of distance or area are required.

This product is generated from the USDA-NRCS certified data as of the version date(s) listed below.

Soil Survey Area: Aspen-Gypsum Area, Colorado, Parts of Eagle, Garfield, and Pitkin Counties
 Survey Area Data: Version 16, Aug 29, 2025

Soil map units are labeled (as space allows) for map scales 1:50,000 or larger.

Date(s) aerial images were photographed: Sep 5, 2021—Sep 7, 2021

The orthophoto or other base map on which the soil lines were compiled and digitized probably differs from the background imagery displayed on these maps. As a result, some minor shifting of map unit boundaries may be evident.

Hydrologic Soil Group

Map unit symbol	Map unit name	Rating	Acres in AOI	Percent of AOI
6	Almy loam, 1 to 12 percent slopes	B	6.4	100.0%
Totals for Area of Interest			6.4	100.0%

Description

Hydrologic soil groups are based on estimates of runoff potential. Soils are assigned to one of four groups according to the rate of water infiltration when the soils are not protected by vegetation, are thoroughly wet, and receive precipitation from long-duration storms.

The soils in the United States are assigned to four groups (A, B, C, and D) and three dual classes (A/D, B/D, and C/D). The groups are defined as follows:

Group A. Soils having a high infiltration rate (low runoff potential) when thoroughly wet. These consist mainly of deep, well drained to excessively drained sands or gravelly sands. These soils have a high rate of water transmission.

Group B. Soils having a moderate infiltration rate when thoroughly wet. These consist chiefly of moderately deep or deep, moderately well drained or well drained soils that have moderately fine texture to moderately coarse texture. These soils have a moderate rate of water transmission.

Group C. Soils having a slow infiltration rate when thoroughly wet. These consist chiefly of soils having a layer that impedes the downward movement of water or soils of moderately fine texture or fine texture. These soils have a slow rate of water transmission.

Group D. Soils having a very slow infiltration rate (high runoff potential) when thoroughly wet. These consist chiefly of clays that have a high shrink-swell potential, soils that have a high water table, soils that have a claypan or clay layer at or near the surface, and soils that are shallow over nearly impervious material. These soils have a very slow rate of water transmission.

If a soil is assigned to a dual hydrologic group (A/D, B/D, or C/D), the first letter is for drained areas and the second is for undrained areas. Only the soils that in their natural condition are in group D are assigned to dual classes.

Rating Options

Aggregation Method: Dominant Condition

Component Percent Cutoff: None Specified

APPENDIX F

Onsite Drainage

Historic and Developed Stormwater Runoff Table

1215 Chambers Avenue Storage

Eagle, CO

Stormwater Runoff

Type B soils (per USDA)- entire onsite property

Basins	Area (Acre)	Area (sqft)	Area Impervious	Area Grass	RCN	TC (hours)	Q2 (cfs)	Q5 (cfs)	Q25 (cfs)	Q50 (cfs)	Q100 (cfs)
Contributing Basins											
5	0.05	2196	0.00	0.05	69	0.10	0.00	0.00	0.00	0.00	0.00
5a	0.05	2094	0.00	0.05	69	0.10	0.00	0.00	0.00	0.00	0.00
5b	0.12	5100	0.00	0.12	69	0.10	0.00	0.00	0.00	0.00	0.05
5c	0.06	2818	0.00	0.06	69	0.10	0.00	0.00	0.00	0.00	0.00
5d	0.05	2362	0.00	0.05	69	0.10	0.00	0.00	0.00	0.00	0.00
4e	0.60	25960	0.60	0.00	98	0.10	0.78	0.94	1.34	1.58	1.73
4w	0.40	17302	0.40	0.00	98	0.10	0.52	0.63	0.90	1.06	1.16
2e	0.40	17263	0.40	0.00	98	0.10	0.52	0.63	0.90	1.06	1.16
2w	0.43	18620	0.43	0.00	98	0.10	0.56	0.67	0.95	1.12	1.24
C	0.04	1845	0.03	0.01	89	0.10	0.00	0.00	0.05	0.07	0.08
B	0.37	15908	0.30	0.07	91	0.10	0.24	0.33	0.57	0.71	0.81
A	0.24	10529	0.20	0.04	92	0.10	0.18	0.24	0.40	0.49	0.56
1	0.47	20581	0.47	0.00	98	0.10	0.61	0.73	1.04	1.22	1.35
Roofs											
1-R	0.34	15014	0.34	0.00	98	0.10	0.44	0.53	0.75	0.89	0.98
2-R	0.30	13119	0.30	0.00	98	0.10	0.39	0.47	0.67	0.79	0.87
3-R	0.17	7608	0.17	0.00	98	0.10	0.22	0.27	0.38	0.45	0.50
4-R	0.33	14480	0.33	0.00	98	0.10	0.43	0.52	0.74	0.87	0.96
5-R	0.41	17754	0.41	0.00	98	0.10	0.53	0.64	0.91	1.07	1.18
6-R	0.29	12466	0.29	0.00	98	0.10	0.37	0.45	0.64	0.75	0.83
7-R	0.32	13750	0.32	0.00	98	0.10	0.41	0.50	0.71	0.84	0.92
Loading Docks											
L-1	0.08	3419	0.08	0.00	98	0.10	0.11	0.13	0.19	0.22	0.24
L-2	0.05	2071	0.05	0.00	98	0.10	0.07	0.08	0.11	0.13	0.15
L-3	0.03	1344	0.03	0.00	98	0.10	0.00	0.05	0.07	0.08	0.09
L-4	0.03	1100	0.03	0.00	98	0.10	0.00	0.05	0.07	0.08	0.09
L-5	0.12	5383	0.12	0.00	98	0.10	0.16	0.19	0.27	0.32	0.35
L-6	0.03	1220	0.03	0.00	98	0.10	0.00	0.05	0.07	0.08	0.09
L-7	0.10	4220	0.10	0.00	98	0.10	0.13	0.16	0.23	0.27	0.29
TOTAL DEVELOPED	5.87		5.43	0.45			6.67	8.26	11.96	14.15	15.68
Offsite											
O1	184.2		0	184.200	56	0.45	0.00	0.26	1.90	7.95	10.60
Historic											
Historic	6.30	274,460	0	6.30	69	0.123	0	0.81	2.92	4.68	5.16

APPENDIX G

Onsite Drainage

TR55 Developed Flowrate Calculations

--- Identification Data ---

```

User:      MW                      Date:      1/29/2026
Project:   1215 CHAMBERS           Units:     English
SubTitle: Historic Runoff         Areal Units: Acres
State:    Colorado
County:   Eagle
Filename:  <new file>
    
```

--- Sub-Area Data ---

Name	Description	Reach	Area(ac)	RCN	Tc
historic		Outlet	6.3	69	.123

Total area: 6.30 (ac)

--- Storm Data --

Rainfall Depth by Rainfall Return Period

2-Yr (in)	5-Yr (in)	10-Yr (in)	25-Yr (in)	50-Yr (in)	100-Yr (in)	-Yr (in)
1.4	1.8	2.0	2.4	2.8	2.9	.0

```

Storm Data Source:      User-provided custom storm data
Rainfall Distribution Type:  Type II
Dimensionless Unit Hydrograph: <standard>
    
```

```

=====
MW                      1215 CHAMBERS
                        Historic Runoff
                        Eagle County, Colorado
    
```

Watershed Peak Table

Sub-Area or Reach Identifier	Peak Flow by Rainfall Return Period				
	2-Yr (cfs)	5-Yr (cfs)	25-Yr (cfs)	50-Yr (cfs)	100-Yr (cfs)
SUBAREAS					
historic	.00	0.81	2.92	4.68	5.16
REACHES					
OUTLET	.00	0.81	2.92	4.68	5.16

```

=====
MW                      1215 CHAMBERS
                        Historic Runoff
    
```

Eagle County, Colorado

Sub-Area Summary Table

Sub-Area Identifier	Drainage Area (ac)	Time of Concentration (hr)	Curve Number	Receiving Reach	Sub-Area Description
historic	6.30	0.123	69	Outlet	
Total Area:		6.30 (ac)			

=====
 MW 1215 CHAMBERS
 Historic Runoff
 Eagle County, Colorado

Sub-Area Time of Concentration Details

Sub-Area Identifier/	Flow Length (ft)	Slope (ft/ft)	Mannings's n	End Area (sq ft)	Wetted Perimeter (ft)	Velocity (ft/sec)	Travel Time (hr)
historic SHEET	100	0.2500	0.150				0.090
SHALLOW	380	0.0400	0.050				0.033
Time of Concentration							.123

=====
 MW 1215 CHAMBERS
 Historic Runoff
 Eagle County, Colorado

Sub-Area Land Use and Curve Number Details

Sub-Area Identifier	Land Use	Hydrologic Soil Group	Sub-Area Area (ac)	Curve Number
historic	Open space; grass cover 50% to 75%	(fair) B	6.3	69
Total Area / Weighted Curve Number			6.3	69

WinTR-55 Current Data Description

--- Identification Data ---

User: MW Date: 1/29/2026
 Project: 1215 CHAMBERS Units: English
 SubTitle: Developed- basins 1 - C Areal Units: Acres
 State: Colorado
 County: Eagle
 Filename: O:\Eagle\1215 Chambers Storage-2021\dwg\Drainage\TR55\developed basins 1-C.w55

--- Sub-Area Data ---

Name	Description	Reach	Area(ac)	RCN	Tc
Basin C		Outlet	0.04	89	0.100
Basin B		Outlet	0.37	91	0.100
Basin A		Outlet	0.24	92	0.100
Basin 1		Outlet	0.47	98	0.100

Total area: 1.12 (ac)

--- Storm Data ---

Rainfall Depth by Rainfall Return Period

2-Yr (in)	5-Yr (in)	10-Yr (in)	25-Yr (in)	50-Yr (in)	100-Yr (in)	-Yr (in)
1.1	1.3	1.5	1.8	2.1	2.3	.0

Storm Data Source: User-provided custom storm data
 Rainfall Distribution Type: Type II
 Dimensionless Unit Hydrograph: <standard>

MW 1215 CHAMBERS
 Developed- basins 1 - C
 Eagle County, Colorado

Watershed Peak Table

Sub-Area or Reach Identifier	Peak Flow by Rainfall Return Period				
	2-Yr (cfs)	5-Yr (cfs)	25-Yr (cfs)	50-Yr (cfs)	100-Yr (cfs)
SUBAREAS					
Basin C	.00	.00	0.05	0.07	0.08
Basin B	0.24	0.33	0.57	0.71	0.81
Basin A	0.18	0.24	0.40	0.49	0.56
Basin 1	0.61	0.73	1.04	1.22	1.35

REACHES

Eagle County, Colorado

Sub-Area Land Use and Curve Number Details

Sub-Area Identifier	Land Use	Hydrologic Soil Group	Sub-Area Area (ac)	Curve Number
Basin C	Open space; grass cover > 75% (good)	B	.01	61
	Paved parking lots, roofs, driveways	B	.03	98
	Total Area / Weighted Curve Number		.04 ===	89 ==
Basin B	Open space; grass cover > 75% (good)	B	.07	61
	Paved parking lots, roofs, driveways	B	.3	98
	Total Area / Weighted Curve Number		.37 ===	91 ==
Basin A	Open space; grass cover > 75% (good)	B	.04	61
	Paved parking lots, roofs, driveways	B	.2	98
	Total Area / Weighted Curve Number		.24 ===	92 ==
Basin 1	Paved parking lots, roofs, driveways	B	.47	98
	Total Area / Weighted Curve Number		.47 ===	98 ==

=====

WinTR-55 Current Data Description

basins 2, 4, 5

--- Identification Data ---

User: MW Date: 1/29/2026
 Project: 1215 CHAMBERS Units: English
 SubTitle: Developed- basins 2 - 5 Areal Units: Acres
 State: Colorado
 County: Eagle
 Filename: O:\Eagle\1215 Chambers Storage-2021\dwg\Drainage\TR55\developed basins 2-5.w55

--- Sub-Area Data ---

Name	Description	Reach	Area(ac)	RCN	Tc
Basin 5		Outlet	0.05	69	0.100
5A		Outlet	0.05	69	0.100
5b		Outlet	0.12	69	0.100
5c		Outlet	0.06	69	0.100
5d		Outlet	0.05	69	0.100
4e		Outlet	0.6	98	0.100
4w		Outlet	0.4	98	0.100
2e		Outlet	0.4	98	0.100
2w		Outlet	0.43	98	0.100

Total area: 2.16 (ac)

--- Storm Data ---

Rainfall Depth by Rainfall Return Period

2-Yr (in)	5-Yr (in)	10-Yr (in)	25-Yr (in)	50-Yr (in)	100-Yr (in)	-Yr (in)
1.1	1.3	1.5	1.8	2.1	2.3	.0

Storm Data Source: User-provided custom storm data
 Rainfall Distribution Type: Type II
 Dimensionless Unit Hydrograph: <standard>

=====

MW 1215 CHAMBERS
 Developed- basins 2 - 5
 Eagle County, Colorado

Watershed Peak Table

Sub-Area or Reach Identifier	Peak Flow by Rainfall Return Period				
	2-Yr (cfs)	5-Yr (cfs)	25-Yr (cfs)	50-Yr (cfs)	100-Yr (cfs)

SUBAREAS					
Basin 5	.00	.00	.00	.00	.00
5A	.00	.00	.00	.00	.00
5b	.00	.00	.00	.00	0.05
5c	.00	.00	.00	.00	.00
5d	.00	.00	.00	.00	.00
4e	0.78	0.94	1.34	1.58	1.73
4w	0.52	0.63	0.90	1.06	1.16
2e	0.52	0.63	0.90	1.06	1.16
2w	0.56	0.67	0.95	1.12	1.24
REACHES					
OUTLET	2.38	2.87	4.09	4.81	5.29

=====

MW

1215 CHAMBERS
Developed- basins 2 - 5
Eagle County, Colorado

Sub-Area Summary Table

Sub-Area Identifier	Drainage Area (ac)	Time of Concentration (hr)	Curve Number	Receiving Reach	Sub-Area Description

Basin 5	.05	0.100	69	Outlet	
5A	.05	0.100	69	Outlet	
5b	.12	0.100	69	Outlet	
5c	.06	0.100	69	Outlet	
5d	.05	0.100	69	Outlet	
4e	.60	0.100	98	Outlet	
4w	.40	0.100	98	Outlet	
2e	.40	0.100	98	Outlet	
2w	.43	0.100	98	Outlet	

Total Area: 2.16 (ac)

=====

MW 1215 CHAMBERS
Developed- basins 2 - 5
Eagle County, Colorado

Sub-Area Time of Concentration Details

Sub-Area Identifier/	Flow Length (ft)	Slope (ft/ft)	Mannings's n	End Area (sq ft)	Wetted Perimeter (ft)	Velocity (ft/sec)	Travel Time (hr)
Basin 5							
User-provided							0.100
					Time of Concentration		0.100 =====
5A							
User-provided							0.100
					Time of Concentration		0.100 =====
5b							
User-provided							0.100
					Time of Concentration		0.100 =====
5c							
User-provided							0.100
					Time of Concentration		0.100 =====
5d							
User-provided							0.100
					Time of Concentration		0.100 =====
4e							
User-provided							0.100
					Time of Concentration		0.100 =====
4w							
User-provided							0.100

Time of Concentration 0.100
 =====

2e User-provided 0.100

Time of Concentration 0.100
 =====

2w User-provided 0.100

Time of Concentration 0.100
 =====

=====

MW 1215 CHAMBERS
 Developed- basins 2 - 5
 Eagle County, Colorado

Sub-Area Land Use and Curve Number Details

Sub-Area Identifier	Land Use	Hydrologic Soil Group	Sub-Area Area (ac)	Curve Number
Basin 5	Open space; grass cover 50% to 75%	(fair) B	.05	69
	Total Area / Weighted Curve Number		.05 ===	69 ==
5A	Open space; grass cover 50% to 75%	(fair) B	.05	69
	Total Area / Weighted Curve Number		.05 ===	69 ==
5b	Open space; grass cover 50% to 75%	(fair) B	.12	69
	Total Area / Weighted Curve Number		.12 ===	69 ==
5c	Open space; grass cover 50% to 75%	(fair) B	.06	69
	Total Area / Weighted Curve Number		.06 ===	69 ==
5d	Open space; grass cover 50% to 75%	(fair) B	.05	69
	Total Area / Weighted Curve Number		.05	69

			===	==
4e	Paved parking lots, roofs, driveways	B	.6	98
	Total Area / Weighted Curve Number		.6	98
			==	==
4w	Paved parking lots, roofs, driveways	B	.4	98
	Total Area / Weighted Curve Number		.4	98
			==	==
2e	Paved parking lots, roofs, driveways	B	.4	98
	Total Area / Weighted Curve Number		.4	98
			==	==
2w	Paved parking lots, roofs, driveways	B	.43	98
	Total Area / Weighted Curve Number		.43	98
			===	==

=====

--- Identification Data ---

User: MW Date: 1/29/2026
 Project: 1215 CHAMBERS Units: English
 SubTitle: Developed- loading docks Areal Units: Acres
 State: Colorado
 County: Eagle
 Filename: O:\Eagle\1215 Chambers Storage-2021\dwg\Drainage\TR55\developed loading docks.w55

--- Sub-Area Data ---

Name	Description	Reach	Area(ac)	RCN	Tc
Dock 1		Outlet	0.08	98	0.100
Dock 2		Outlet	0.05	98	0.100
Dock 3		Outlet	0.03	98	0.100
Dock 4		Outlet	0.03	98	0.100
Dock 5		Outlet	0.12	98	0.100
Dock 6		Outlet	0.03	98	0.100
Dock 7		Outlet	0.1	98	0.100

Total area: .44 (ac)

--- Storm Data --

Rainfall Depth by Rainfall Return Period

2-Yr (in)	5-Yr (in)	10-Yr (in)	25-Yr (in)	50-Yr (in)	100-Yr (in)	-Yr (in)
1.1	1.3	1.5	1.8	2.1	2.3	.0

Storm Data Source: User-provided custom storm data
 Rainfall Distribution Type: Type II
 Dimensionless Unit Hydrograph: <standard>

MW 1215 CHAMBERS
 Developed- loading docks
 Eagle County, Colorado

Watershed Peak Table

Sub-Area or Reach Identifier	Peak Flow by Rainfall Return Period				
	2-Yr (cfs)	5-Yr (cfs)	25-Yr (cfs)	50-Yr (cfs)	100-Yr (cfs)
SUBAREAS					
Dock 1	0.11	0.13	0.19	0.22	0.24
Dock 2	0.07	0.08	0.11	0.13	0.15
Dock 3	.00	0.05	0.07	0.08	0.09
Dock 4	.00	0.05	0.07	0.08	0.09

Dock 5	0.16	0.19	0.27	0.32	0.35
Dock 6	.00	0.05	0.07	0.08	0.09
Dock 7	0.13	0.16	0.23	0.27	0.29
REACHES					
OUTLET	0.46	0.71	1.01	1.19	1.31

=====

MW 1215 CHAMBERS
 Developed- loading docks
 Eagle County, Colorado

Sub-Area Summary Table

Sub-Area Identifier	Drainage Area (ac)	Time of Concentration (hr)	Curve Number	Receiving Reach	Sub-Area Description
Dock 1	.08	0.100	98	Outlet	
Dock 2	.05	0.100	98	Outlet	
Dock 3	.03	0.100	98	Outlet	
Dock 4	.03	0.100	98	Outlet	
Dock 5	.12	0.100	98	Outlet	
Dock 6	.03	0.100	98	Outlet	
Dock 7	.10	0.100	98	Outlet	

Total Area: .44 (ac)

=====

MW 1215 CHAMBERS
 Developed- loading docks
 Eagle County, Colorado

Sub-Area Time of Concentration Details

Sub-Area Identifier/	Flow Length (ft)	Slope (ft/ft)	Mannings's n	End Area (sq ft)	Wetted Perimeter (ft)	Velocity (ft/sec)	Travel Time (hr)
Dock 1							
User-provided							0.100
							Time of Concentration 0.100
							=====
Dock 2							
User-provided							0.100
							Time of Concentration 0.100
							=====
Dock 3							
User-provided							0.100
							Time of Concentration 0.100
							=====
Dock 4							

```

User-provided                                0.100
                                           Time of Concentration  0.100
                                           =====
Dock 5
  User-provided                                0.100
                                           Time of Concentration  0.100
                                           =====
Dock 6
  User-provided                                0.100
                                           Time of Concentration  0.100
                                           =====
Dock 7
  User-provided                                0.100
                                           Time of Concentration  0.100
                                           =====

```

=====

```

MW                1215 CHAMBERS
                  Developed- loading docks
                  Eagle County, Colorado

```

Sub-Area Land Use and Curve Number Details

Sub-Area Identifier	Land Use	Hydrologic Soil Group	Sub-Area Area (ac)	Curve Number
Dock 1	CN directly entered by user	-	.08	98
	Total Area / Weighted Curve Number		.08 ===	98 ==
Dock 2	CN directly entered by user	-	.05	98
	Total Area / Weighted Curve Number		.05 ===	98 ==
Dock 3	CN directly entered by user	-	.03	98
	Total Area / Weighted Curve Number		.03 ===	98 ==
Dock 4	CN directly entered by user	-	.03	98
	Total Area / Weighted Curve Number		.03 ===	98 ==
Dock 5	CN directly entered by user	-	.12	98
	Total Area / Weighted Curve Number		.12 ===	98 ==
Dock 6	CN directly entered by user	-	.03	98
	Total Area / Weighted Curve Number		.03 ===	98 ==
Dock 7	CN directly entered by user	-	.1	98

Total Area / Weighted Curve Number

.1
==

98
==

=====

WinTR-55 Current Data Description

--- Identification Data ---

User: MW Date: 1/29/2026
 Project: 1215 CHAMBERS Units: English
 SubTitle: Developed- loading docks Areal Units: Acres
 State: Colorado
 County: Eagle
 Filename: O:\Eagle\1215 Chambers Storage-2021\dwg\Drainage\TR55\developed loading docks.w55

--- Sub-Area Data ---

Name	Description	Reach	Area(ac)	RCN	Tc
Dock 1		Outlet	0.08	98	0.100
Dock 2		Outlet	0.05	98	0.100
Dock 3		Outlet	0.03	98	0.100
Dock 4		Outlet	0.03	98	0.100
Dock 5		Outlet	0.12	98	0.100
Dock 6		Outlet	0.03	98	0.100
Dock 7		Outlet	0.1	98	0.100

Total area: .44 (ac)

--- Storm Data ---

Rainfall Depth by Rainfall Return Period

2-Yr (in)	5-Yr (in)	10-Yr (in)	25-Yr (in)	50-Yr (in)	100-Yr (in)	-Yr (in)
1.1	1.3	1.5	1.8	2.1	2.3	.0

Storm Data Source: User-provided custom storm data
 Rainfall Distribution Type: Type II
 Dimensionless Unit Hydrograph: <standard>

MW 1215 CHAMBERS
 Developed- loading docks
 Eagle County, Colorado

Watershed Peak Table

Sub-Area or Reach Identifier	Peak Flow by Rainfall Return Period				
	2-Yr (cfs)	5-Yr (cfs)	25-Yr (cfs)	50-Yr (cfs)	100-Yr (cfs)
SUBAREAS					
Dock 1	0.11	0.13	0.19	0.22	0.24
Dock 2	0.07	0.08	0.11	0.13	0.15
Dock 3	.00	0.05	0.07	0.08	0.09
Dock 4	.00	0.05	0.07	0.08	0.09

Dock 5	0.16	0.19	0.27	0.32	0.35
Dock 6	.00	0.05	0.07	0.08	0.09
Dock 7	0.13	0.16	0.23	0.27	0.29
REACHES					
OUTLET	0.46	0.71	1.01	1.19	1.31

=====

MW 1215 CHAMBERS
 Developed- loading docks
 Eagle County, Colorado

Sub-Area Summary Table

Sub-Area Identifier	Drainage Area (ac)	Time of Concentration (hr)	Curve Number	Receiving Reach	Sub-Area Description
Dock 1	.08	0.100	98	Outlet	
Dock 2	.05	0.100	98	Outlet	
Dock 3	.03	0.100	98	Outlet	
Dock 4	.03	0.100	98	Outlet	
Dock 5	.12	0.100	98	Outlet	
Dock 6	.03	0.100	98	Outlet	
Dock 7	.10	0.100	98	Outlet	

Total Area: .44 (ac)

=====

MW 1215 CHAMBERS
 Developed- loading docks
 Eagle County, Colorado

Sub-Area Time of Concentration Details

Sub-Area Identifier/	Flow Length (ft)	Slope (ft/ft)	Mannings's n	End Area (sq ft)	Wetted Perimeter (ft)	Velocity (ft/sec)	Travel Time (hr)
Dock 1							
User-provided							0.100
							Time of Concentration 0.100
							=====
Dock 2							
User-provided							0.100
							Time of Concentration 0.100
							=====
Dock 3							
User-provided							0.100
							Time of Concentration 0.100
							=====
Dock 4							

```

User-provided                                0.100
                                           Time of Concentration  0.100
                                           =====
Dock 5
  User-provided                                0.100
                                           Time of Concentration  0.100
                                           =====
Dock 6
  User-provided                                0.100
                                           Time of Concentration  0.100
                                           =====
Dock 7
  User-provided                                0.100
                                           Time of Concentration  0.100
                                           =====

```

=====

```

MW                1215 CHAMBERS
                  Developed- loading docks
                  Eagle County, Colorado

```

Sub-Area Land Use and Curve Number Details

Sub-Area Identifier	Land Use	Hydrologic Soil Group	Sub-Area Area (ac)	Curve Number
Dock 1	CN directly entered by user	-	.08	98
	Total Area / Weighted Curve Number		.08 ===	98 ==
Dock 2	CN directly entered by user	-	.05	98
	Total Area / Weighted Curve Number		.05 ===	98 ==
Dock 3	CN directly entered by user	-	.03	98
	Total Area / Weighted Curve Number		.03 ===	98 ==
Dock 4	CN directly entered by user	-	.03	98
	Total Area / Weighted Curve Number		.03 ===	98 ==
Dock 5	CN directly entered by user	-	.12	98
	Total Area / Weighted Curve Number		.12 ===	98 ==
Dock 6	CN directly entered by user	-	.03	98
	Total Area / Weighted Curve Number		.03 ===	98 ==
Dock 7	CN directly entered by user	-	.1	98

Total Area / Weighted Curve Number

.1
==

98
==

=====

WinTR-55 Current Data Description

Offsite Chambers
Avenue upstream
of Ex. inlet

--- Identification Data ---

User: MW Date: 2/3/2026
 Project: 1215 CHAMBERS Units: English
 SubTitle: Developed- Chambers Offsite Areal Units: Acres
 State: Colorado
 County: Eagle
 Filename: O:\Eagle\1215 Chambers Storage-2021\dwg\Drainage\TR55\Chambers Ave-offsite.w55

--- Sub-Area Data ---

Name	Description	Reach	Area(ac)	RCN	Tc
Chambers A	upstream of inlet	Outlet	0.4	91	0.100

Total area: .40 (ac)

--- Storm Data ---

Rainfall Depth by Rainfall Return Period

2-Yr (in)	5-Yr (in)	10-Yr (in)	25-Yr (in)	50-Yr (in)	100-Yr (in)	-Yr (in)
1.1	1.3	1.5	1.8	2.1	2.3	.0

Storm Data Source: User-provided custom storm data
 Rainfall Distribution Type: Type II
 Dimensionless Unit Hydrograph: <standard>

=====
 MW 1215 CHAMBERS
 Developed- Chambers Offsite
 Eagle County, Colorado

Watershed Peak Table

Sub-Area or Reach Identifier	Peak Flow by Rainfall Return Period				
	2-Yr (cfs)	5-Yr (cfs)	25-Yr (cfs)	50-Yr (cfs)	100-Yr (cfs)

SUBAREAS					
Chambers A	0.26	0.36	0.62	0.78	0.88
REACHES					
OUTLET	0.26	0.36	0.62	0.78	0.88

=====
 MW 1215 CHAMBERS
 Developed- Chambers Offsite

Eagle County, Colorado

Sub-Area Summary Table

Sub-Area Identifier	Drainage Area (ac)	Time of Concentration (hr)	Curve Number	Receiving Reach	Sub-Area Description
Chambers A	.40	0.100	91	Outlet	upstream of inlet
Total Area: .40 (ac)					

=====
 MW 1215 CHAMBERS
 Developed- Chambers Offsite
 Eagle County, Colorado

Sub-Area Time of Concentration Details

Sub-Area Identifier/	Flow Length (ft)	Slope (ft/ft)	Mannings's n	End Area (sq ft)	Wetted Perimeter (ft)	Velocity (ft/sec)	Travel Time (hr)
Chambers A User-provided							0.100
							Time of Concentration 0.100

=====
 MW 1215 CHAMBERS
 Developed- Chambers Offsite
 Eagle County, Colorado

Sub-Area Land Use and Curve Number Details

Sub-Area Identifier	Land Use	Hydrologic Soil Group	Sub-Area Area (ac)	Curve Number
Chambers A	Open space; grass cover > 75%	(good) B	.08	61
	Paved parking lots, roofs, driveways	B	.32	98
Total Area / Weighted Curve Number			.4	91

APPENDIX H

Onsite Drainage

Detention Pond Storage Volume

1215 Chambers

DETENTION POND - DETENTION STORAGE VOLUME

POND 1

Elevation	Area (ft ²)	Avg. Area (ft ²)	Depth (ft)	Volume (ft ³)	Cumulative Volume (ft ³)	Cumulative Volume (Ac-ft)	Cumulative Volume (Gallons)
6659	145	0	0	0	0	0.000	0
6660	239	192	1	192	192	0.004	1,436
6661	350	295	1	295	487	0.011	3,639
6662	473	412	1	412	898	0.021	6,717
6663	613	543	1	543	1,441	0.033	10,779

APPENDIX I

Onsite Drainage

Manning's Eqn For Onsite Storm Sewer and Curb/Gutter



TECHNICAL SPECIFICATION

DIMENSION KEY

- A: LENGTH - 48" (4 FT)
- B: MIN. INVERT DEPTH
- C: MAX. INVERT DEPTH
- D: UPSTREAM BODY DEPTH
- E: DOWNSTREAM BODY DEPTH
- F: BOTTOM OUTLET DEPTH—0.65"
- G: GRATE WIDTH—6"
- H: LEVELOC™ RE-BAR SUPPORT WIDTH—10.185"

**NDS-DURA SLOPE™ 6" WIDE X 48" LONG
LOAD CLASS A - D****

****LOAD CLASS "D" REQUIRES DS-200H
DUCTILE IRON FRAME**

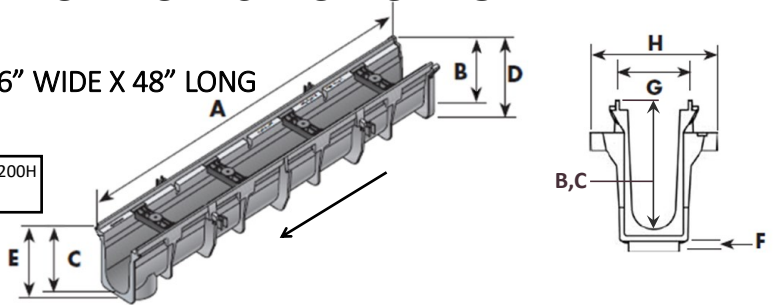

(*1) BASED ON HEAD OF 1/2" ABOVE THE GRATE. ENGINEER OF RECORD TO VERIFY DOWNSTREAM CAPACITIES.
 (*2) BOTTOM OUTLET FLOW RATES LISTED BASED ON USING DS-126, (3.58" I.D.) FOR SEWER & DRAIN PIPE. WHEN SCHEDULE-40 IS USED (4" I.D.), ADD 25% TO THE BOTTOM OUTLET FLOW RATES.
 (*3) END OUTLET FLOW RATES BASED ON 4.07" I.D.

6" WIDE x 48" LONG			OVERALL BODY DEPTH (Inches)		INVERT (Inches)		MAXIMUM FLOW RATE			WEIGHT	BOTTOM OUTLET FLOW RATE (*1)		END OUTLET FLOW RATE (*1)	
PART NUMBER	SLOPE		UPSTREAM MIN (D)	DOWNSTREAM MAX (E)	UPSTREAM MIN (B)	DOWNSTREAM MAX (C)	GPM	LPS	CFS	Lbs	GPM (*2)	CFS (*2)	GPM (*3)	CFS (*3)
○ DS-090N	NEUTRAL	0.0%	5.4	5.8	4.75	4.75	154	9.7	0.34	7.5	100	0.22	102	0.23
○ DS-091	SLOPED	0.7%	5.7	5.8	4.75	5.08	154	9.7	0.34	7.5	100	0.22	102	0.23
○ DS-091N	NEUTRAL	0.0%	5.7	6.1	5.08	5.08	170	10.7	0.38	7.8	103	0.23	106	0.24
○ DS-092	SLOPED	0.7%	6.1	6.1	5.08	5.42	170	10.7	0.38	7.9	103	0.23	106	0.24
○ DS-093	SLOPED	0.7%	6.4	6.4	5.42	5.76	187	11.8	0.42	8.3	106	0.24	112	0.25
○ DS-094	SLOPED	0.7%	6.7	6.8	5.76	6.09	205	12.9	0.46	8.6	109	0.24	116	0.26
○ DS-094N	NEUTRAL	0.0%	6.7	7.1	6.09	6.09	223	14.1	0.50	8.9	112	0.25	120	0.27
○ DS-095	SLOPED	0.7%	7.0	7.1	6.09	6.43	223	14.1	0.50	9.0	112	0.25	120	0.27
○ DS-096	SLOPED	0.7%	7.4	7.5	6.43	6.76	237	15.0	0.53	9.4	115	0.26	125	0.28
○ DS-097	SLOPED	0.7%	7.7	7.8	6.76	7.10	256	16.2	0.57	9.7	117	0.26	129	0.29
○ DS-097N	NEUTRAL	0.0%	7.7	8.1	7.10	7.10	273	17.2	0.61	10.0	121	0.27	134	0.30
○ DS-098	SLOPED	0.7%	8.0	8.1	7.10	7.44	273	17.2	0.61	10.1	121	0.27	134	0.30
○ DS-099	SLOPED	0.7%	8.4	8.5	7.44	7.77	299	18.2	0.65	10.5	123	0.27	137	0.31
○ DS-100	SLOPED	0.7%	8.7	8.8	7.77	8.11	307	19.4	0.68	10.9	125	0.28	141	0.31
○ DS-100N	NEUTRAL	0.0%	8.7	9.1	8.11	8.11	325	20.5	0.72	11.2	128	0.29	145	0.32
○ DS-101	SLOPED	0.7%	9.1	9.1	8.11	8.44	325	20.5	0.72	11.2	128	0.29	145	0.32
○ DS-102	SLOPED	0.7%	9.4	9.5	8.44	8.78	342	21.6	0.76	11.6	130	0.29	149	0.33
○ DS-103	SLOPED	0.7%	9.7	9.8	8.78	9.12	359	22.6	0.80	12.0	133	0.30	152	0.34
○ DS-103N	NEUTRAL	0.0%	9.7	10.1	9.12	9.12	376	23.7	0.85	12.3	135	0.30	156	0.35
○ DS-104	SLOPED	0.7%	10.1	10.1	9.12	9.45	376	23.7	0.85	12.3	135	0.30	156	0.35
○ DS-105	SLOPED	0.7%	10.4	10.5	9.45	9.79	393	24.8	0.88	12.7	138	0.31	159	0.35
○ DS-106	SLOPED	0.7%	10.7	10.8	9.79	10.12	410	25.9	0.91	13.1	140	0.31	162	0.36
○ DS-106N	NEUTRAL	0.0%	10.7	11.1	10.12	10.12	428	27.0	0.95	13.4	142	0.32	166	0.37
○ DS-107	SLOPED	0.7%	11.1	11.1	10.12	10.46	428	27.0	0.95	13.4	142	0.32	166	0.37
○ DS-108	SLOPED	0.7%	11.4	11.5	10.46	10.80	445	28.1	0.99	13.8	144	0.32	169	0.38
○ DS-109	SLOPED	0.7%	11.7	11.8	10.80	11.13	462	29.1	1.03	14.2	147	0.33	172	0.38
○ DS-109N	NEUTRAL	0.0%	11.7	12.2	11.13	11.13	479	30.2	1.07	14.5	149	0.33	175	0.39
○ DS-110	SLOPED	0.7%	12.1	12.2	11.13	11.47	479	30.2	1.07	14.6	149	0.33	175	0.39
○ DS-111	SLOPED	0.7%	12.4	12.5	11.47	11.80	497	31.4	1.11	15.0	151	0.34	178	0.40
○ DS-112	SLOPED	0.7%	12.7	12.8	11.80	12.14	514	32.4	1.15	15.3	153	0.34	181	0.40
○ DS-112N	NEUTRAL	0.0%	12.8	13.2	12.14	12.14	531	33.5	1.18	15.6	155	0.35	184	0.41
○ DS-113	SLOPED	0.7%	13.1	13.2	12.14	12.48	531	33.5	1.18	15.7	155	0.35	184	0.41
○ DS-114	SLOPED	0.7%	13.4	13.5	12.48	12.81	548	34.6	1.22	16.1	157	0.35	187	0.42

SPECIFICATION:

- NDS DURA SLOPE™ IS A 6" WIDE, 48" LONG TRENCH DRAIN SYSTEM WITH A BUILT-IN SLOPE OF 0.7%. EACH CHANNEL SECTION IS MOLDED OF GRAY STRUCTURAL FOAM POLYETHYLENE WITH UV INHIBITORS. THE SYSTEM CONSISTS OF (24) PRE-SLOPED AND (9) NEUTRAL 4-FOOT CHANNEL SECTIONS WITH TONGUE AND GROOVE DURA LOC™ JOINTS THAT ENSURE PRECISE ALIGNMENT.
- OUTLETS CAN BE CONFIGURED AS BOTTOM, END OUTLET OR USE WITH A CATCH BASIN. SEE ACCESSORIES PAGE.
- ALL CHANNELS REQUIRE CONCRETE ENCASEMENT (SEE WWW.NDSPRO.COM FOR INSTALLATION DETAILS)

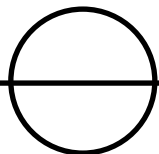

DURA SLOPE™ TRENCH DRAIN

6" WIDE HDPE CHANNEL DRAIN—48" LONG, LOAD CLASS A-D**

FOR PRODUCT ASSISTANCE, CONTACT NDS TECHNICAL SERVICE AT techservice@ndspro.com, DESIGN ASSISTANCE—designworx@ndspro.com
 851 N. HARVARD AVE. LINDSAY, CA 93247 WWW.NDSPRO.COM 1-800-726-1994 "3"

BASIN 4E- TRENCH DRAIN

Channel Calculator

Given Input Data:

Shape Trapezoidal
Solving for Depth of Flow
Flowrate 1.7300 cfs
Slope 0.0100 ft/ft
Manning's n 0.0130
Height 4.2000 in
Bottom width 0.0000 in
Left slope 0.0350 ft/ft (V/H)
Right slope 0.5000 ft/ft (V/H)

100 year event

Computed Results:

Depth 2.5335 in
Velocity 2.5391 fps
Full Flowrate 6.6599 cfs
Flow area 0.6813 ft2
Flow perimeter 78.0945 in
Hydraulic radius 1.2563 in
Top width 77.4521 in
Area 1.8725 ft2
Perimeter 129.4650 in
Percent full 60.3209 %

BASIN 4W- TRENCH DRAIN

Channel Calculator

Given Input Data:

Shape Trapezoidal
Solving for Depth of Flow
Flowrate 1.1600 cfs
Slope 0.0100 ft/ft
Manning's n 0.0130
Height 4.2000 in
Bottom width 0.0000 in
Left slope 0.0410 ft/ft (V/H)
Right slope 0.5000 ft/ft (V/H)

Computed Results:

Depth 2.3053 in
Velocity 2.3821 fps
Full Flowrate 5.7436 cfs
Flow area 0.4870 ft2
Flow perimeter 61.4289 in
Hydraulic radius 1.1416 in
Top width 60.8374 in
Area 1.6164 ft2
Perimeter 111.9166 in
Percent full 54.8881 %

BASIN 2E- TRENCH DRAIN

Channel Calculator

Given Input Data:

Shape	Trapezoidal
Solving for	Depth of Flow
Flowrate	1.1600 cfs
Slope	0.0100 ft/ft
Manning's n	0.0130
Height	4.2000 in
Bottom width	0.0000 in
Left slope	0.0410 ft/ft (V/H)
Right slope	0.5000 ft/ft (V/H)

Computed Results:

Depth	2.3053 in
Velocity	2.3821 fps
Full Flowrate	5.7436 cfs
Flow area	0.4870 ft ²
Flow perimeter	61.4289 in
Hydraulic radius	1.1416 in
Top width	60.8374 in
Area	1.6164 ft ²
Perimeter	111.9166 in
Percent full	54.8881 %

BASIN 2W- TRENCH DRAIN

Channel Calculator

Given Input Data:

Shape	Trapezoidal
Solving for	Depth of Flow
Flowrate	1.2400 cfs
Slope	0.0100 ft/ft
Manning's n	0.0130
Height	4.2000 in
Bottom width	0.0000 in
Left slope	0.0400 ft/ft (V/H)
Right slope	0.5000 ft/ft (V/H)

Computed Results:

Depth	2.3434 in
Velocity	2.4086 fps
Full Flowrate	5.8772 cfs
Flow area	0.5148 ft ²
Flow perimeter	63.8714 in
Hydraulic radius	1.1607 in
Top width	63.2713 in
Area	1.6538 ft ²
Perimeter	114.4755 in
Percent full	55.7948 %

18" HDPE STORM SEWER COLLECTOR

Manning Pipe Calculator

Given Input Data:

Shape	Circular
Solving for	Flowrate
Diameter	18.0000 in
Depth	17.0000 in
Slope	0.0172 ft/ft
Manning's n	0.0090

Computed Results:

Flowrate	21.3992 cfs
Area	1.7671 ft ²
Wetted Area	1.7285 ft ²
Wetted Perimeter	47.9828 in
Perimeter	56.5487 in
Velocity	12.3800 fps
Hydraulic Radius	5.1874 in
Percent Full	94.4444 %
Full flow Flowrate	19.8991 cfs
Full flow velocity	11.2606 fps

capacity of collector exceeds
total developed flow

APPENDIX J

Manning's Eqn for Access Drive Volume

manni ng-trapezoi d-100 year-1.5percent. txt

Channel Cal cul ator

10 ft wide concrete
drainage channel
with 5" depth to
flowline

Given Input Data:

Shape	Trapezoi dal
Sol vi ng for	Depth of Fl ow
Fl owrate	10.6000 cfs
Slope	0.0150 ft/ft
Manni ng' s n	0.0130
Hei ght	4.8000 in
Bottom width	0.0000 in
Left slope	0.0200 ft/ft (V/H)
Ri ght slope	0.0200 ft/ft (V/H)

100 year event

Computed Result s:

Depth	2.9651 in
Vel oci ty	3.4723 fps
Full Fl owrate	38.2977 cfs
Fl ow area	3.0527 ft ²
Fl ow peri meter	296.5704 in
Hydraul ic radi us	1.4823 in
Top width	296.5111 in
Area	8.0000 ft ²
Peri meter	480.0960 in
Percent full	61.7732 %

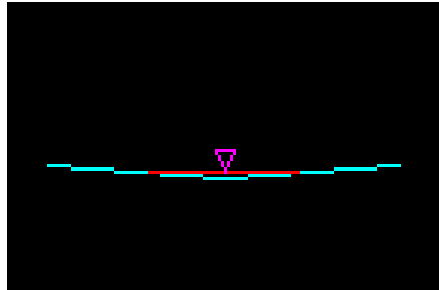

APPENDIX K

MHFD Capacity for 1/2 Street and Existing inlet on Chambers Ave.

INLET MANAGEMENT

Project: 1215 Chamber Ave
Minor: 10-year
Major: 100-year

Worksheet Protected

INLET NAME	Inlet Ex
Inlet Application (Street or Area)	STREET
Hydraulic Condition	On Grade
Inlet Type	CDOT/Denver 13 Combination
Number of Inlet Units	1

USER-DEFINED INPUT

User-Defined Peak Flows	
Minor Peak Flow, Q (cfs)	0.88
Major Peak Flow, Q (cfs)	11.48
Bypass (Carry-Over) Flow from Upstream	
Receive Bypass Flow from:	User-Defined
Bypass Flow Description (Optional):	none
Minor Bypass Flow Received, Q _b (cfs)	0.00
Major Bypass Flow Received, Q _b (cfs)	0.00

Inlets must be organized from upstream (left)

CALCULATED OUTPUT

Minor Total Design Peak Flow, Q (cfs)	0.88
Major Total Design Peak Flow, Q (cfs)	11.48
Minor Inlet Interception Capacity, Q _a (cfs)	0.75
Major Inlet Interception Capacity, Q _a (cfs)	3.29
Minor Flow Bypassed Downstream, Q _b (cfs)	0.13
Major Flow Bypassed Downstream, Q _b (cfs)	8.19
Minor Flow Capture Percentage, C%	85%
Major Flow Capture Percentage, C%	29%

ALLOWABLE CAPACITY FOR ONE-HALF OF STREET (Minor & Major Storm)

(Based on Regulated Criteria for Maximum Allowable Flow Depth and Spread)

Project: 1215 Chamber Ave

Inlet ID: Inlet Ex

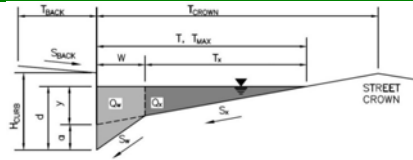

Gutter Geometry:					
Maximum Allowable Width for Spread Behind Curb	$T_{BACK} = 0.0$ ft				
Side Slope Behind Curb (leave blank for no conveyance credit behind curb)	$S_{BACK} =$ ft/ft				
Manning's Roughness Behind Curb (typically between 0.012 and 0.020)	$n_{BACK} =$				
Height of Curb at Gutter Flow Line	$H_{CURB} = 6.00$ inches				
Distance from Curb Face to Street Crown	$T_{CROWN} = 19.5$ ft				
Gutter Width	$W = 2.00$ ft				
Street Transverse Slope	$S_x = 0.020$ ft/ft				
Gutter Cross Slope (typically 2 inches over 24 inches or 0.083 ft/ft)	$S_w = 0.083$ ft/ft				
Street Longitudinal Slope - Enter 0 for sump condition	$S_o = 0.015$ ft/ft				
Manning's Roughness for Street Section (typically between 0.012 and 0.020)	$n_{STREET} = 0.013$				
Max. Allowable Spread for Minor & Major Storm	$T_{MAX} =$ <table border="1"><tr><td>Minor Storm</td><td>Major Storm</td></tr><tr><td>19.5</td><td>19.5</td></tr></table> ft	Minor Storm	Major Storm	19.5	19.5
Minor Storm	Major Storm				
19.5	19.5				
Max. Allowable Depth at Gutter Flowline for Minor & Major Storm	$d_{MAX} =$ <table border="1"><tr><td>Minor Storm</td><td>Major Storm</td></tr><tr><td>6.0</td><td>6.0</td></tr></table> inches	Minor Storm	Major Storm	6.0	6.0
Minor Storm	Major Storm				
6.0	6.0				
Allow Flow Depth at Street Crown (check box for yes, leave blank for no)	<input type="checkbox"/> <input type="checkbox"/>				
MINOR STORM Allowable Capacity is based on Depth Criterion					
MAJOR STORM Allowable Capacity is based on Depth Criterion					
Minor storm max. allowable capacity GOOD - greater than the design peak flow of 0.88 cfs on sheet 'Inlet Management'	$Q_{allow} =$ <table border="1"><tr><td>Minor Storm</td><td>Major Storm</td></tr><tr><td>20.8</td><td>20.8</td></tr></table> cfs	Minor Storm	Major Storm	20.8	20.8
Minor Storm	Major Storm				
20.8	20.8				
Major storm max. allowable capacity GOOD - greater than the design peak flow of 11.48 cfs on sheet 'Inlet Management'					

Crub and gutter and 1/2 the street can contain almost twice the offsite 100 year flow

INLET ON A CONTINUOUS GRADE

MHFD-Inlet, Version 6.00 (August 2025)

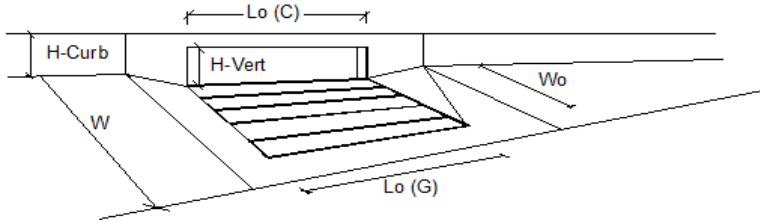

Design Information (Input)	MINOR		MAJOR	
Type of Inlet	CDOT/Denver 13 Combination			
Local Depression (additional to continuous gutter depression 'a')	$a_{LOCAL} =$	2.0	2.0	inches
Total Number of Units in the Inlet (Grate or Curb Opening)	No =	1	1	
Length of a Single Unit Inlet (Grate or Curb Opening)	$L_o =$	3.00	3.00	ft
Width of a Unit Grate (cannot be greater than W, Gutter Width)	$W_o =$	1.73	1.73	ft
Clogging Factor for a Single Unit Grate (typical min. value = 0.5)	$C_f (G) =$	0.50	0.50	
Clogging Factor for a Single Unit Curb Opening (typical min. value = 0.1)	$C_f (C) =$	0.10	0.10	
Street Hydraulics: OK - $Q < Q_{allowable}$ Street Capacity				
Total Inlet Interception Capacity	$Q_i =$	0.8	3.3	cfs
Total Inlet Carry-Over Flow (flow bypassing inlet)	$Q_o =$	0.1	8.2	cfs
Capture Percentage = Q_i/Q_o	C% =	85	29	%

unclogged inlet capacity for Q100 = 4.2 cfs

MAPS

ONSITE DRAINAGE

DRAINAGE AREA MAP

STORM SEWER PLANS
(C3.0 – C3.5)

LEGEND

---	PROPERTY LINE
- - - -	EXISTING CONTOUR
- - - -	EASEMENT
- - - -	PROPOSED CONTOUR
1.5% 06.6'	PROPOSED GRADING, SLOPE/SPOT
1.5% 06.6'	EXISTING GRADING, SLOPE/SPOT
---	PROPOSED STORM SEWER
---	PROPOSED BOULDER RETAINING
---	PROPOSED CONCRETE/ASPHALT

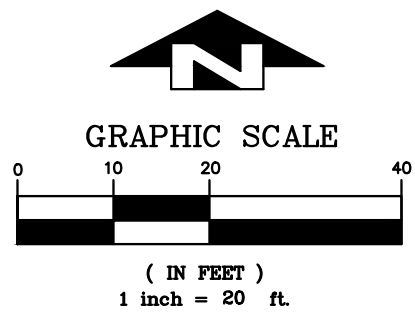

TOPOGRAPHIC INFORMATION WAS PROVIDED BY KIPP LAND SURVEYING

PERIODICALLY MAINTAIN SETTLING BASIN, DETENTION FACILITY AND STORM SEWER MANHOLES & INLETS (INSPECT QUARTERLY FOR FIRST 2 YEARS AN YEARLY AFTER). REMOVE GRATE AND VACUUM SEDIMENT/DEBRIS FROM 12" SUMP IN INLET

MAINTAIN DRAINAGE SWALES SHOWN ON PLAN, TO PROVIDE POSITIVE DRAINAGE AWAY FROM STRUCTURE

ALL STORM INLETS TO BE CONSTRUCTED WITH A 12" SUMP

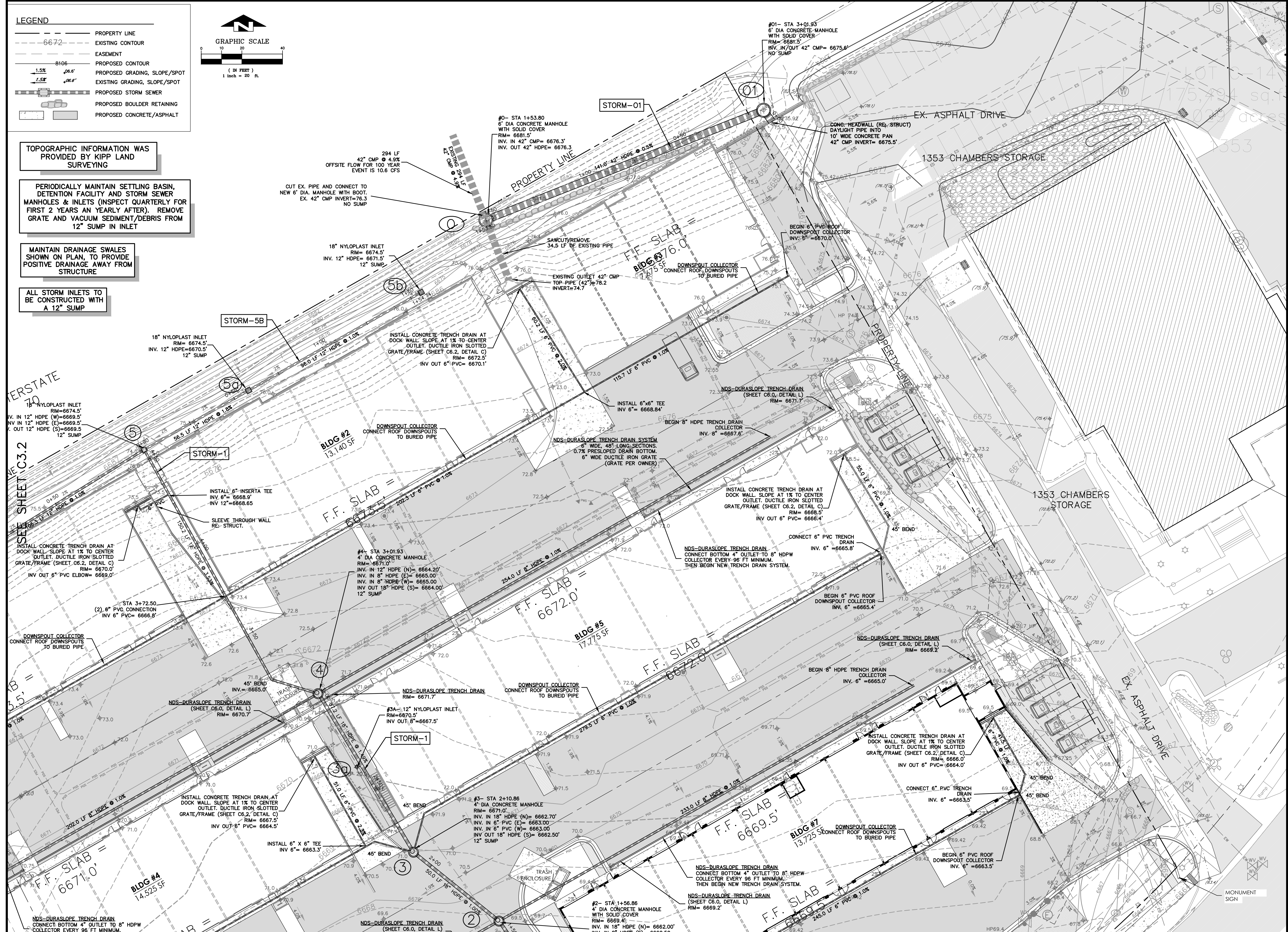

1215 CHAMBERS AVE.
STORAGE FACILITY
EAGLE, CO
STORM PLAN

NO.	DATE	REVISIONS	BY
	01/30/2026	SITE DEVELOPMENT PERMIT	MCW

DESIGNED	DRAWN	CHECKED	DATE
MW	MW	MW	02-11-2025

SHEET C3.1

LEGEND

- PROPERTY LINE
- - - - 6672 EXISTING CONTOUR
- - - - EASEMENT
- - - - PROPOSED CONTOUR
- 1.5% 06.6' PROPOSED GRADING, SLOPE/SPOT
- 1.5% 06.6' EXISTING GRADING, SLOPE/SPOT
- PROPOSED STORM SEWER
- PROPOSED BOULDER RETAINING
- PROPOSED CONCRETE/ASPHALT

GRAPHIC SCALE
(IN FEET)
1 inch = 20 ft.

TOPOGRAPHIC INFORMATION WAS PROVIDED BY KIPP LAND SURVEYING

PERIODICALLY MAINTAIN SETTLING BASIN, DETENTION FACILITY AND STORM SEWER MANHOLES & INLETS (INSPECT QUARTERLY FOR FIRST 2 YEARS AN YEARLY AFTER). REMOVE GRATE AND VACUUM SEDIMENT/DEBRIS FROM 12" SUMP IN INLET

MAINTAIN DRAINAGE SWALES SHOWN ON PLAN, TO PROVIDE POSITIVE DRAINAGE AWAY FROM STRUCTURE

ALL STORM INLETS TO BE CONSTRUCTED WITH A 12" SUMP

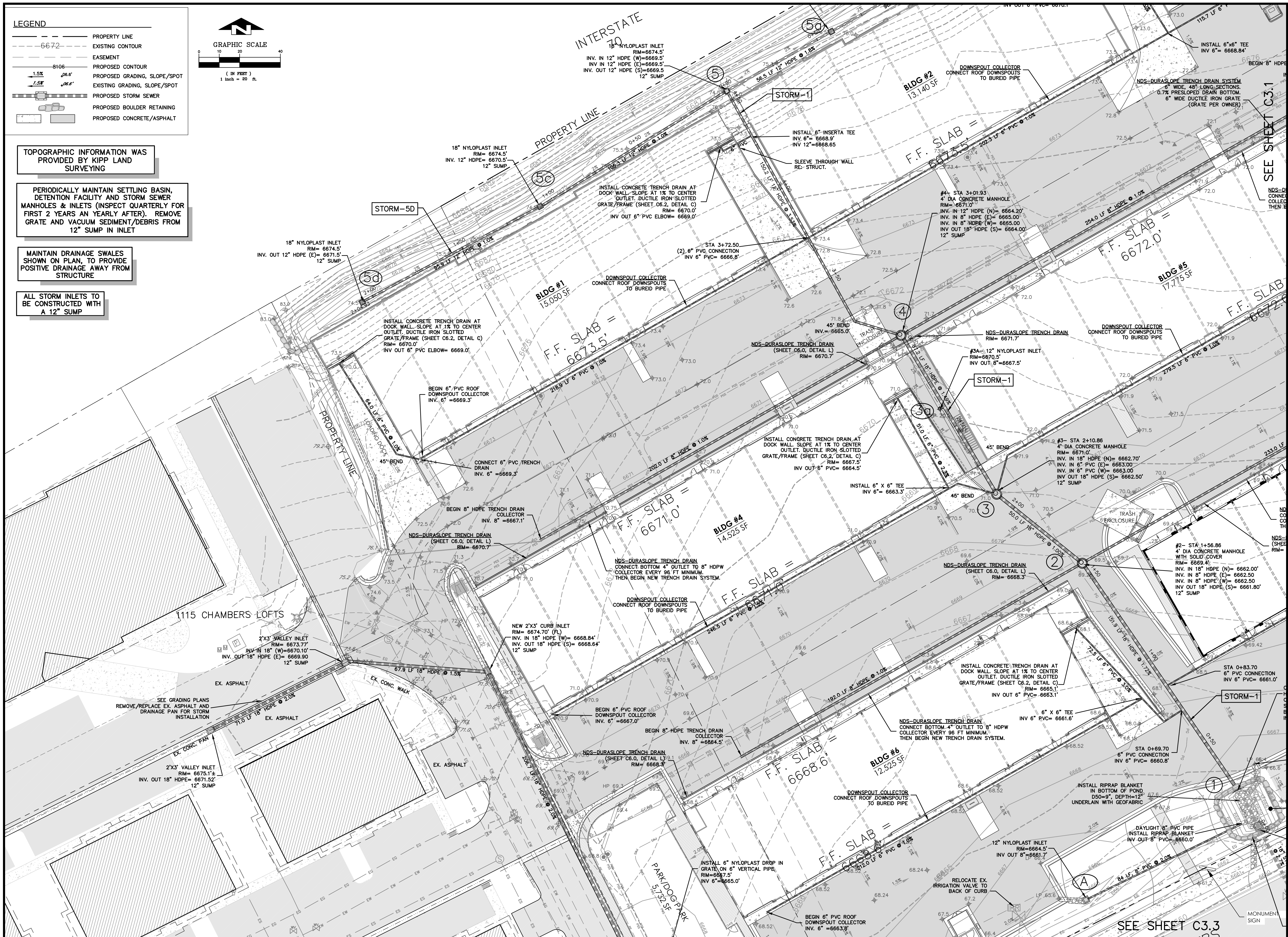

ALPINE ENGINEERING INC.
2500 S. EDWARDS ST. SUITE 100
EAGLE, CO 81632 / 970.996.9373
WWW.ALPINECIVIL.COM

1215 CHAMBERS AVE.
STORAGE FACILITY
EAGLE, CO
STORM PLAN

NO.	DATE	REVISIONS	BY
01	01/30/2026	SITE DEVELOPMENT PERMIT	MCW

DESIGNED	MW	CHECKED	MW	DATE	02-11-2025
DRAWN	MW	JOB NO.			

SHEET C3.2

(SEAL)

C:\Bentley\1215 Chambers Storage\2025\1215 Chambers Storm\1215 Chambers Storm.dwg, 02/11/2025 12:34:15 PM, AutoCAD PDF High Quality Plotter v3

PROFILE: STORM-5D

**PROFILE SCALE:
VERTICAL 1"=20'
HORIZONTAL 1"=20'**

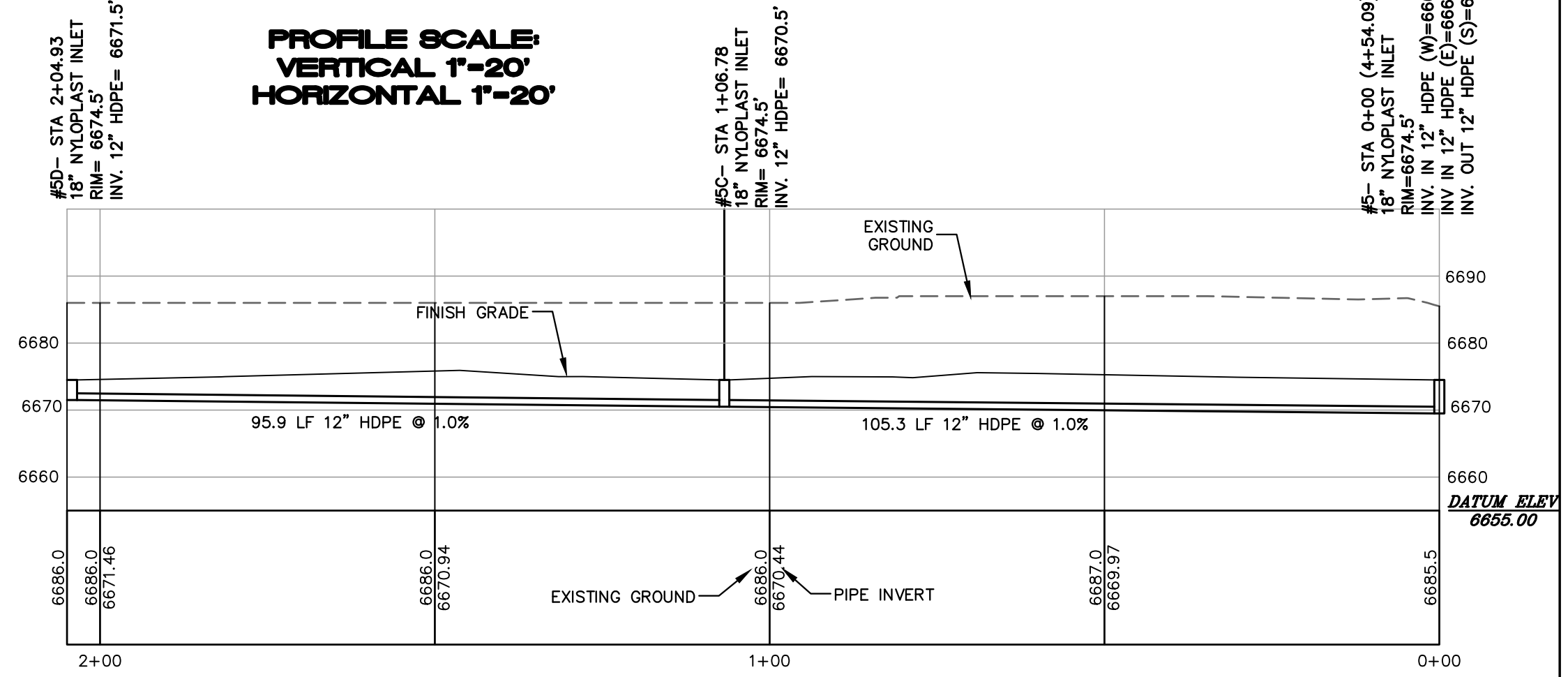

TOPOGRAPHIC INFORMATION WAS PROVIDED BY KIPP LAND SURVEYING

MAINTAIN DRAINAGE SWALES SHOWN ON PLAN, TO PROVIDE POSITIVE DRAINAGE AWAY FROM STRUCTURE

ALL STORM INLETS TO BE CONSTRUCTED WITH A 12" SUMP

PERIODICALLY MAINTAIN SETTLING BASIN, DETENTION FACILITY AND STORM SEWER MANHOLES & INLETS (INSPECT QUARTERLY FOR FIRST 2 YEARS AN YEARLY AFTER). REMOVE GRATE AND VACUUM SEDIMENT/DEBRIS FROM 12" SUMP IN INLET

- LEGEND**
- PROPERTY LINE
 - - - - - EXISTING CONTOUR
 - - - - - EASEMENT
 - - - - - PROPOSED CONTOUR
 - PROPOSED GRADING, SLOPE/SPOT
 - EXISTING GRADING, SLOPE/SPOT
 - PROPOSED STORM SEWER
 - PROPOSED BOULDER RETAINING
 - PROPOSED CONCRETE/ASPHALT

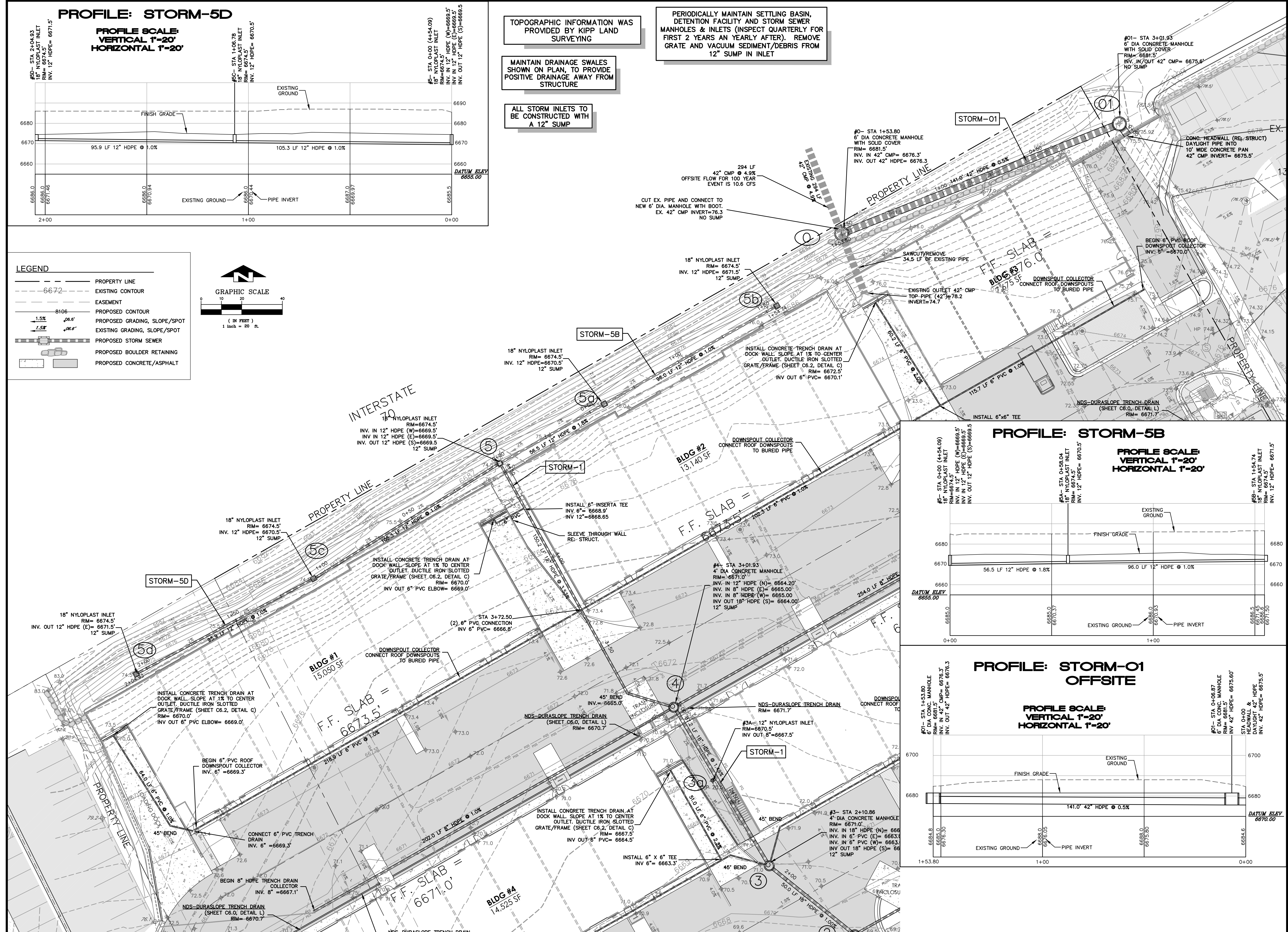
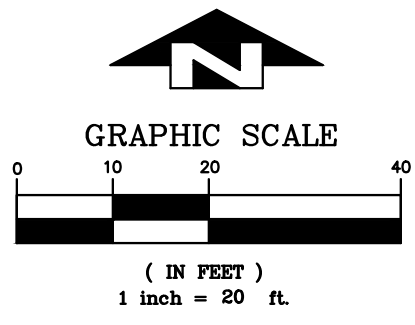

PROFILE: STORM-5B

**PROFILE SCALE:
VERTICAL 1"=20'
HORIZONTAL 1"=20'**

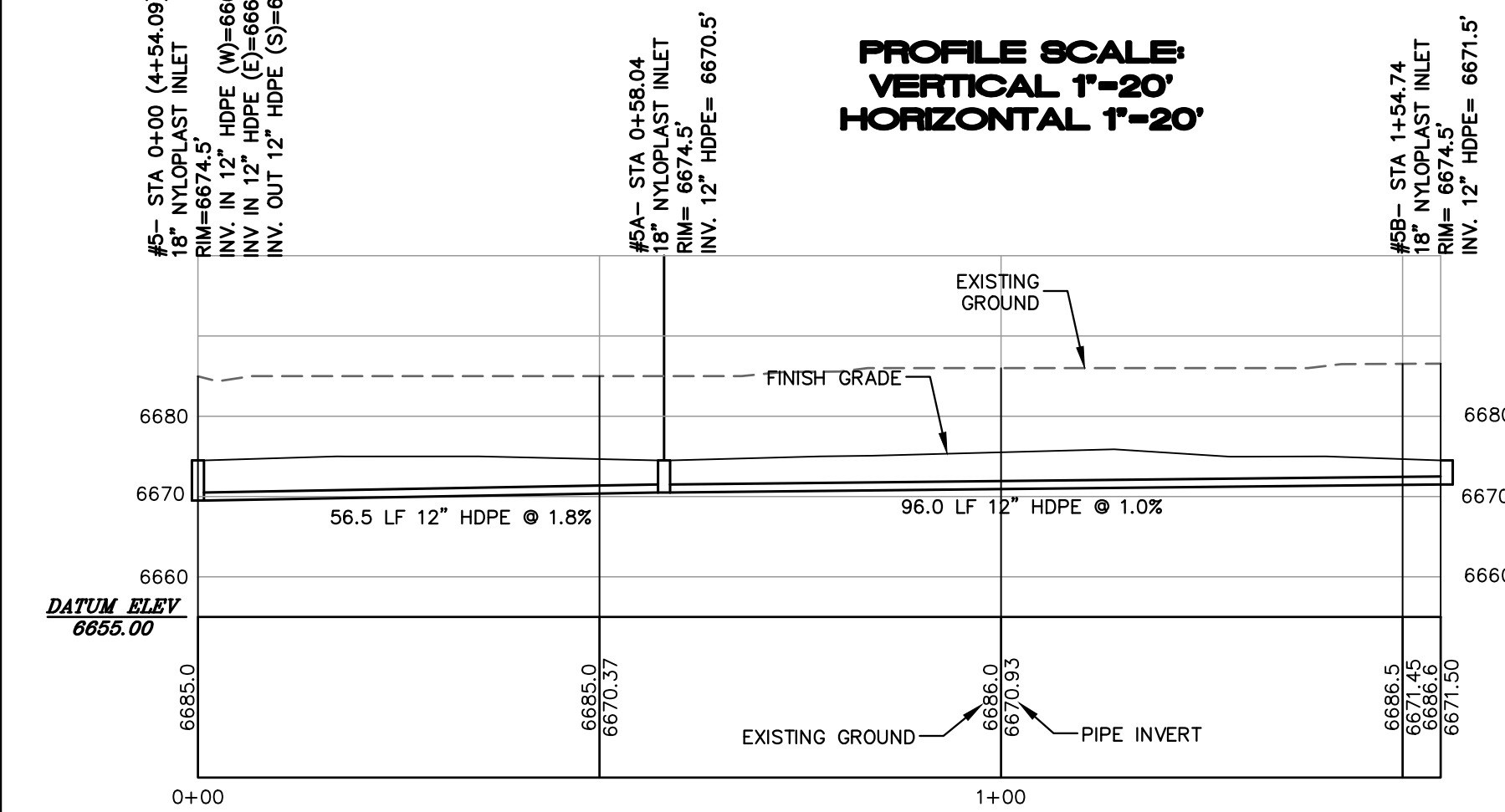

PROFILE: STORM-01 OFFSITE

**PROFILE SCALE:
VERTICAL 1"=20'
HORIZONTAL 1"=20'**

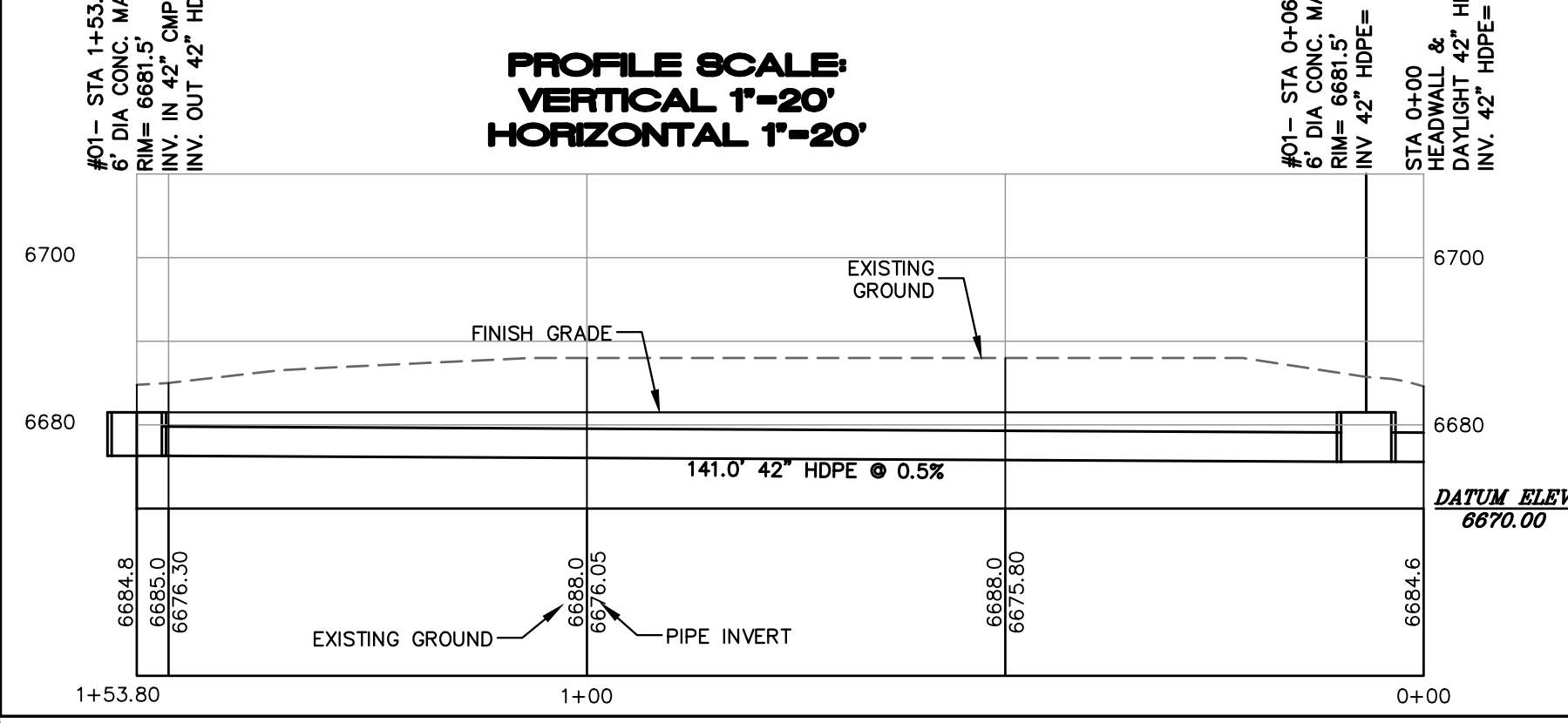

1215 CHAMBERS AVE.
STORAGE FACILITY
EAGLE, CO
STORM PROFILES

NO.	DATE	REVISIONS
	01/30/2026	SITE DEVELOPMENT PERMIT

DESIGNED	DRAWN	CHECKED	JOB NO.	DATE
MW	MW	MW		02-11-2025

SHEET C3.5



(SEAL)

0:\alpin\1215 Chambers Storage\2025\Map\Main\Storm_1215 Chambers.dwg, 1/27/2025, 12:38:47 PM, AutoCAD PDF High Quality Plotter.ctb